



METAL CELLS



FALSE CEILINGS AND COVERINGS



FALSE CEILINGS AND COVERINGS

**INNOVATIVE ARCHITECTURAL SOLUTIONS
HIGH PERFORMANCE SYSTEMS
NEW EXPRESSIVE POSSIBILITIES**

Atena has been conceiving and manufacturing false ceilings, external coverings and high quality marine fittings for over 30 years, producing in its factory in Italy and distributing in over fifty countries, through its dealers and partners.

Without any limit to the technical development, Atena offers innovative solutions to transform the designers vision into real works, all over the world. It stands out for the capability to make executive the most challenging projects by creating special metal bodies for interior and façade architecture.

In addition to the commercial synergies with different European realities, and not only, Atena cooperates with designers and construction companies, following customers at all levels from the idea to the installation; providing a qualified executive design service and specialized consultancy in acoustics, lighting and seismic engineering.

METAL CELLS

FIND OUT THE ATENA
METAL CELLS RANGE, AND CREATE
THE MOST AMAZING OPEN CELL
TECHNICAL PATTERN.

Always modern and in high demand, Atena METAL CELLS represent an effective technical solution to realize metal ceilings with original patterns, in environments such as shops, shopping centers and public areas, where a high percentage of open surface is required.

Light and versatile, the Atena METAL CELLS are available in different models and with various meshes: always a right choice to mask the plenum and enhance the ceiling.

The production includes both integrated solutions and installation with visible structures. In the first case, the open cell modules are perfectly coupled with the bearing elements to create a uniform and homogeneous pattern, while, when T profiles are used the modularity of the configuration stands out.

INDEX

8

OPEN CELL PANELS

LOGICO	pag. 10	BASE 4 EASY LINE	pag. 26
TRIGON	pag. 12	BASE 20 H80	pag. 28
MONOLAMA R-T24	pag. 14	BASE 15	pag. 30
BASE 4 H30 SC	pag. 16	H40 H50	pag. 32
BASE 4 H30 SC DUALGRID	pag. 20	H40 H50 T24	pag. 34
BASE 4 H18 H30	pag. 22	DUALGRID	pag. 36
BASE 4 T15 T24	pag. 24		

38

PERFORMANCES

40

FINISHING AND PERFORATIONS

42

WALL ANGLES AND HANGERS

44

LIGHTING SOLUTIONS

46

WEIGHTS AND PACKAGING

48

CERTIFICATIONS

METAL CELLS

OPEN CELL PANELS



Open cell panels

LOGICO | TRIGON | MONOLAMA R-T24 | BASE 4 H30 SC
BASE 4 H30 SC DUALGRID | BASE 4 H18 | H30 | BASE 4 T15 | T24
BASE 4 EASY LINE | BASE 20 H80 | BASE 15 | H40 | H50
H40 | H50 T24 | DUALGRID

Picture: "Open cell panels" metal ceiling

METAL CELLS

LOGICO

The Atena LOGICO open cell is a clever spring system made up of individually adjustable blades, a nice option to create a smart design especially with blades of different colors and heights.

LOGICO blades are mechanically coupled with a special profile, 1200 mm long properly shaped to house the wire steel springs: an easy way to hang up the modules to the main carriers and dismount the system for fast plenum access.

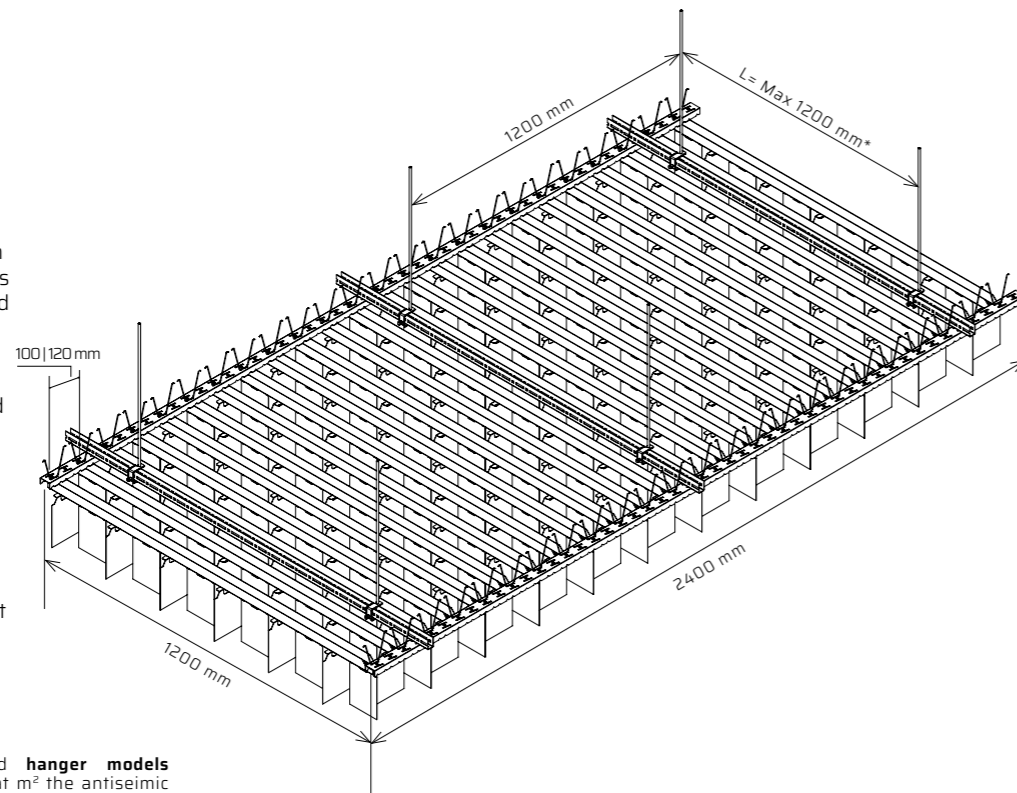

*verify interaxes and hanger models according to the load at m² the antiseismic report and particular conditions when required.

FEATURES

PRODUCT TYPE

Open cell spring system adjustable blades at 90° mechanical coupling without any tools.

OPEN CELL ELEMENTS

Interlocking blades base 100 H100 | 120 | 150 mm pitch 100/120 mm

BLADES MATERIALS

8/10 Steel | Aluminum

INTEGRATED STRUCTURE

"U" shaped and punched profile L=4050 in 15/10 galvanised steel
 Carriers in 8/10 black pre-painted steel
 Main carriers for module coupling L= 2400 mm
 Secondary carriers for blades hanging L= 1200 mm
 Wire steel springs for carriers hanging

HANGERS

Threaded bars and brackets for "U" profiles

COLORS | FINISHING

Atena standard white and silver pre-painted steel
 Atena standard white and silver pre-painted aluminium
 RAL / NCS post-painting

ACCESSORIES

Joints both for carriers and "U" profiles.

OPEN CELL SECTIONS

LOGICO

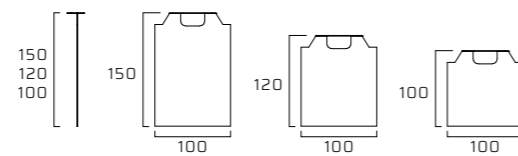

PRIMARY CARRIER

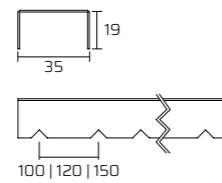

SECONDARY CARRIER

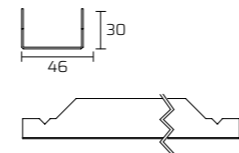

ELEMENTS SECTION

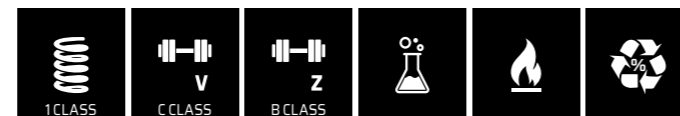
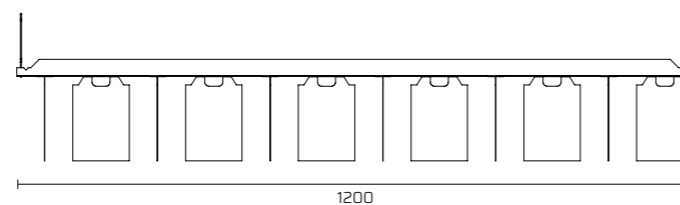

PANELS

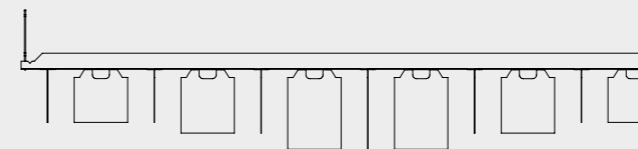

Module hooking and unhooking system through special high-performance wire springs: for frequent system dismantling and easy plenum access.

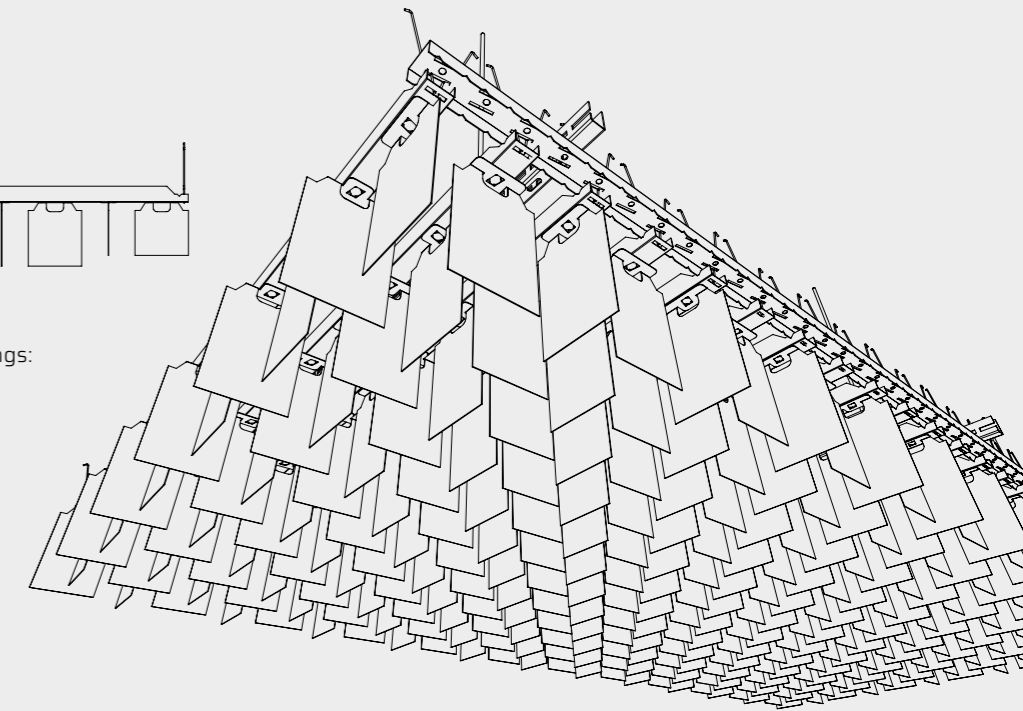

TECHNICAL FEATURES

MODEL	STRUCTURE	LENGHT (mm)	INCIDENCE (pcs/mq)		WEIGHT Kg/m²	BLADES	PITCH	BLADES INCIDENCES		BLADES WEIGHTS		SYSTEM WEIGHT	
			100	120				(pcs/car.)	(pcs/mq)	Ste. 8/10 Kg/m²	All. 8/10 Kg/m²	Ste. Blades Kg/m²	All. Blades Kg/m²
LOGICO	Secondary carrier	1200	8,33	6,94	5,46 4,55	B100 H100	100	12	100	7,22	2,53	13,87	9,17
	Main carrier	2400	0,35	0,35	0,37	B100 H120	100	12	100	8,48	2,97	15,12	9,61
	Main carrier joint	200	0,35	0,35	0,31	B100 H150	100	12	100	10,36	3,63	17,01	10,27
	"U" punched profile	4050	0,21	0,21	0,75	B100 H100	120	10	69,44	5,02	1,76	10,75	7,49
	"U" punched profile joint	200	0,21	0,21	0,04	B100 H120	120	10	69,44	5,89	2,06	11,62	7,79
	Structure total weight					B100 H150	120	10	69,44	7,20	2,52	12,93	8,25

For specific project requirements, the hanger incidence may vary. Please check with the Atena S.p.A technical department.



TRIGON

Atena TRIGON ceiling stands out for the distinctive triangular open cell pattern, which creates a peculiar visual effect that changes triangle in exagon, rhombus or rectangle, giving rise to amazing optical symmetries.

Atena Trigon is made up of rhomboidal panels equipped with a proper supporting structure which, combined with the construction elements, creates a continuous aesthetic effect, without joints between panel and panel.

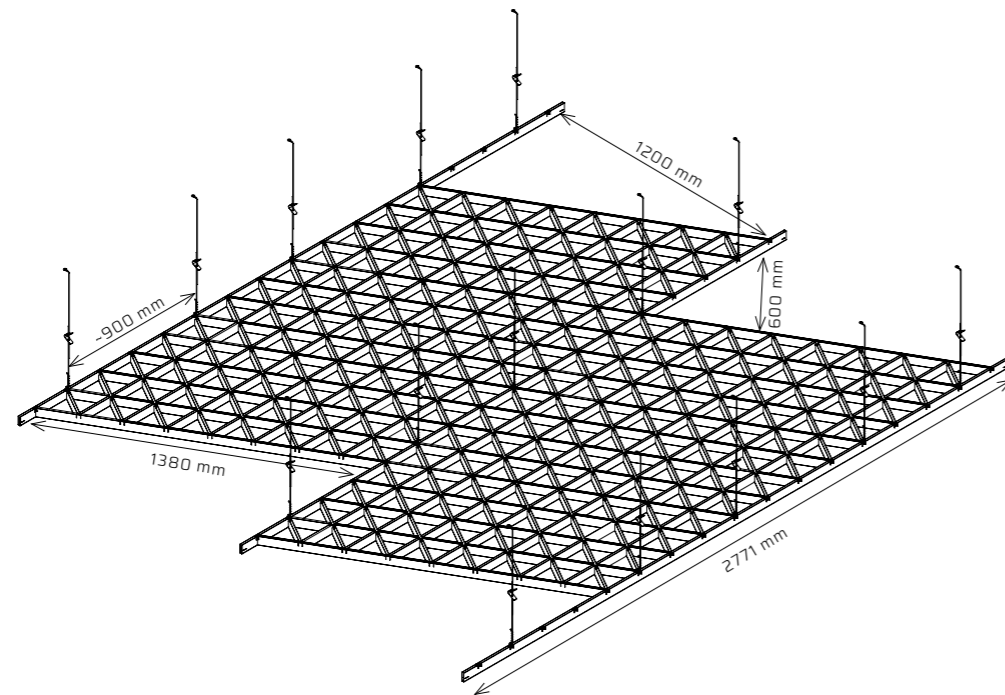

FEATURES

PRODUCT TYPE

-693x1386 mm open cell panels with rhomboid shape

OPEN CELL ELEMENTS

Base 10 H41 interlocking profiles

MATERIALS

5/10 Aluminum

INTEGRATED STRUCTURE

2771 mm main profiles
1380 mm spacer

HANGERS

Standard double hanger Ø4 mm with spring

COLORS | FINISHING

Atena standard white and silver pre-painted aluminum
RAL / NCS post-painting
Wood finishing on request (see page 40)

WALL ANGLES

"C" 25x42x10 mm
With the same material and finishing of the open cell

ACCESSORIES

Triangle shaped recessed spotlights

OPEN CELL SECTIONS

TRIGON

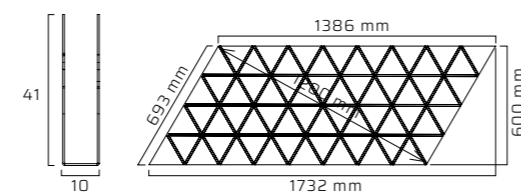

ELEMENTS SECTION

TF SPACER

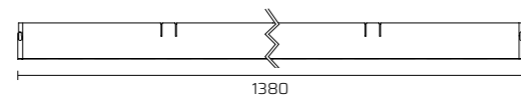

TM MAIN PROFILE

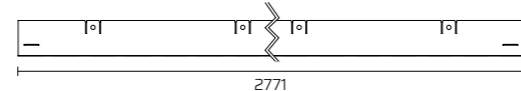

PANELS

The distinctive triangular texture of Atena TRIGON is available in three different meshes: 120x120, 150x150 and 200x200 mm.

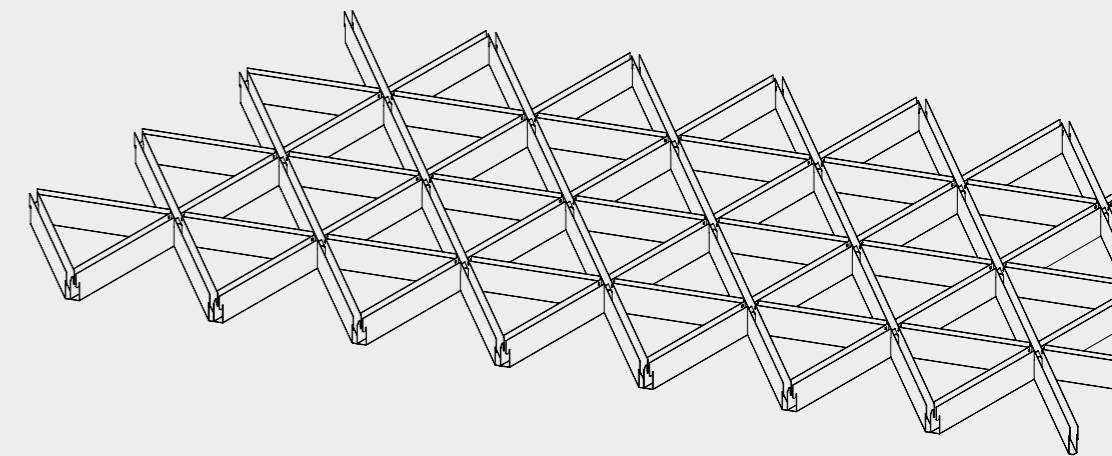

TECHNICAL FEATURES

MODEL	MESHERS	OPEN AREA	ELEMENTS QUALITY FOR ONE PANEL*			PIECES/SQM		LM/SQM	KG/SQM
			LOWER ELEMENTS	INTERMEDIATE ELEMENTS	UPPER ELEMENTS	2771 mm PROFILE	1380 mm PROFILE		
TRIGON	120x120	76,6%	4	9	14	0,252	1,20	25	3,07
	150x150	81%	3	7	11	0,252	1,20	20	2,45
	200x200	85,6%	2	5	7	0,252	1,20	15	1,84

For specific project requirements, the hanger incidence may vary. Please check with the Atena S.p.A technical department.
* System supplied only with assembled panels.

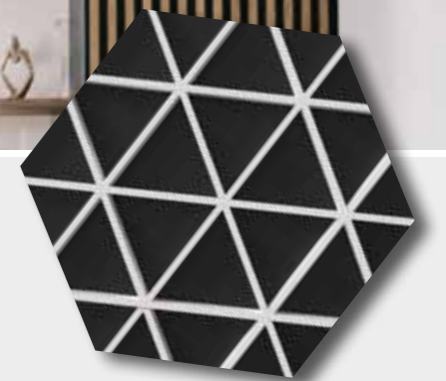

ATENA METAL CELLS | OPEN CELL PANELS

MONOLAMA R-T24

The MONOLAMA R-T24 open cell ceiling stands out for the special shape of its elements which create a uniform matrix of cubic blades with 40 mm height and 40x40 mm mesh.

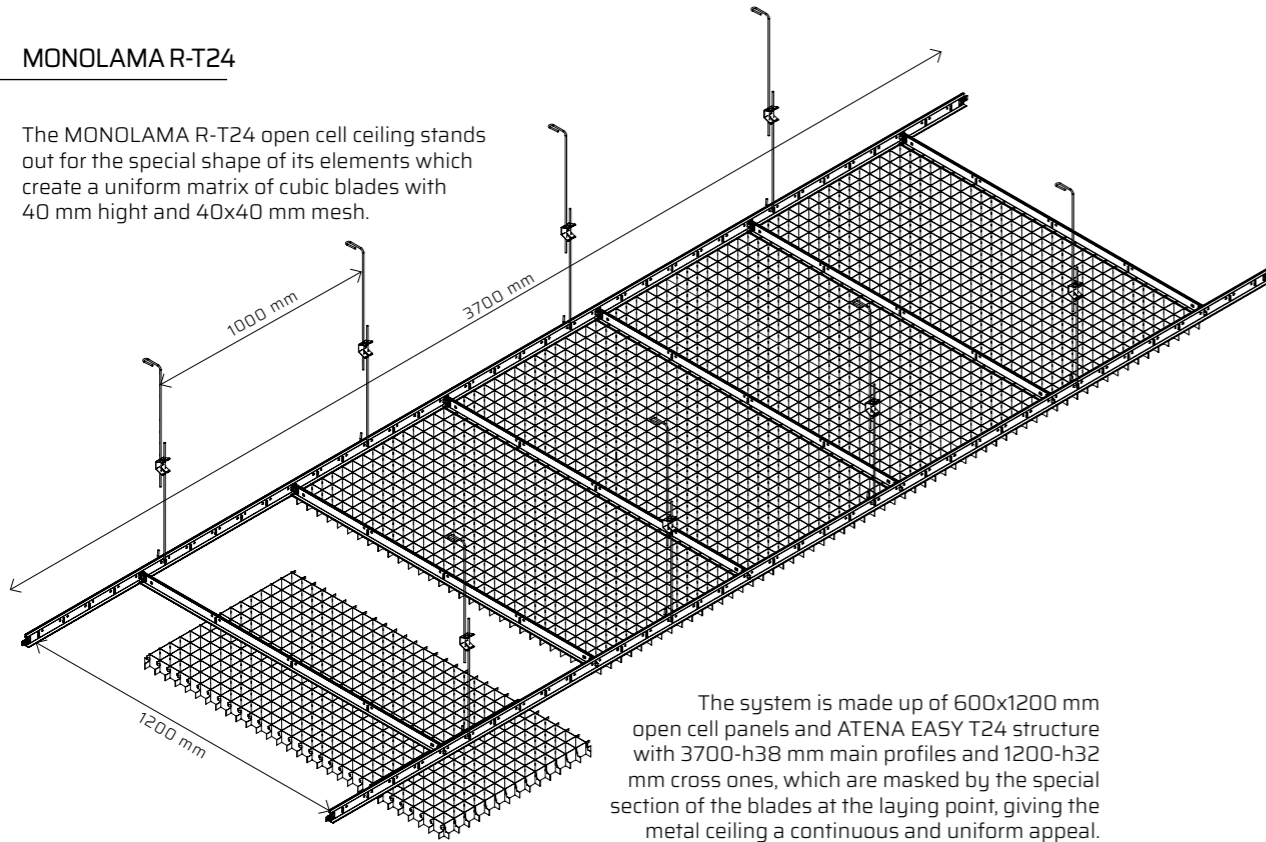

The system is made up of 600x1200 mm open cell panels and ATENA EASY T24 structure with 3700-h38 mm main profiles and 1200-h32 mm cross ones, which are masked by the special section of the blades at the laying point, giving the metal ceiling a continuous and uniform appeal.



FEATURES

PRODUCT TYPE

600x1200 mm open cell panels with regular blades

OPEN CELL ELEMENTS

Interlocking TM-TF profiles

MATERIALS

8/10 Aluminum

INTEGRATED STRUCTURE

Steel Strong Easy T24

T24 main profiles: 3700 mm H38

T24 cross profiles: 1200 mm H38 | H32

HANGERS*

Twister, Nonius, Standard with spring, 90° hanger

COLORS | FINISHING

Atena standard white and silver pre-painted aluminum

RAL / NCS post-painting on both sides

also available with different colored blades

Wood finishing on request (see page 40)

WALL ANGLES

"L" 55x20 mm

8/10 aluminum with the same material and finishing of the open cell

ACCESSORIES

Lighting adapters

OPEN CELL SECTIONS

MONOLAMA R-T24

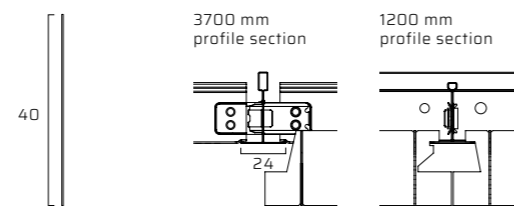

ELEMENTS SECTION

TM CROSS PROFILE

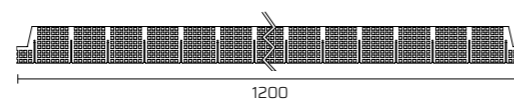

TF MAIN PROFILE

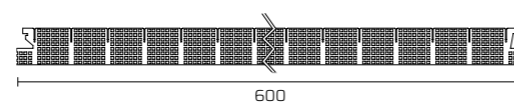

PANELS

The cubic cells qualify the MONOLAMA R-T24

style, which can be realized both with monochrome blades or with polychrome elements. The blades moreover can be made both with smooth and perforated surface choosing among two different perforation patterns.

PERFORATION PATTERN

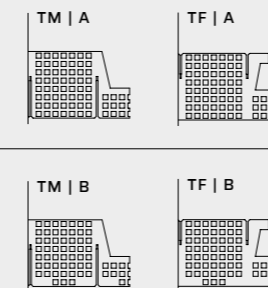

TECHNICAL FEATURES

MODEL	MESH	OPEN AREA	600x1200 PANEL ELEMENTS QUANTITY		ml/m ²	kg/m ²	INCIDENCE		
			TF 600 mm	TM 1200 mm			PANNEL pcs/m ²	3700 ml/m ²	1200 ml/m ²
MONOLAMA R-T24	40x40	96%	30	15	50,00	4,40*	1,39	0,85	0,70

To the open cell weight add the structure weight 3700 h38 - 1200 h32: **kg/m² 0,77** | 3700 h38 - 1200 h38: **kg/m² 0,81**
Weight calculated for Easy Base 24 module 600x1200

For specific project requirements, the hanger incidence may vary. Please check with the Atena S.p.A technical department.



BASE 4 H30 SC

The BASE 4 H30 SC open cell ceiling is made up of closed blades with the distinctive delta section. Blades are equipped with special slots properly shaped to allow an easy insertion of the coupling springs. A great system for this one, to open and keep hooked the modules for plenum inspection and plant maintenance. Panels are available in 600x600mm and 600x1200mm size. Each module is properly conceived to be hooked up to special TSC carriers with pitched cuts for blades centering.

To assure a correct alignment of the carriers, they will be used as spacers to be installed orthogonally at an interaxe of 2400 mm.

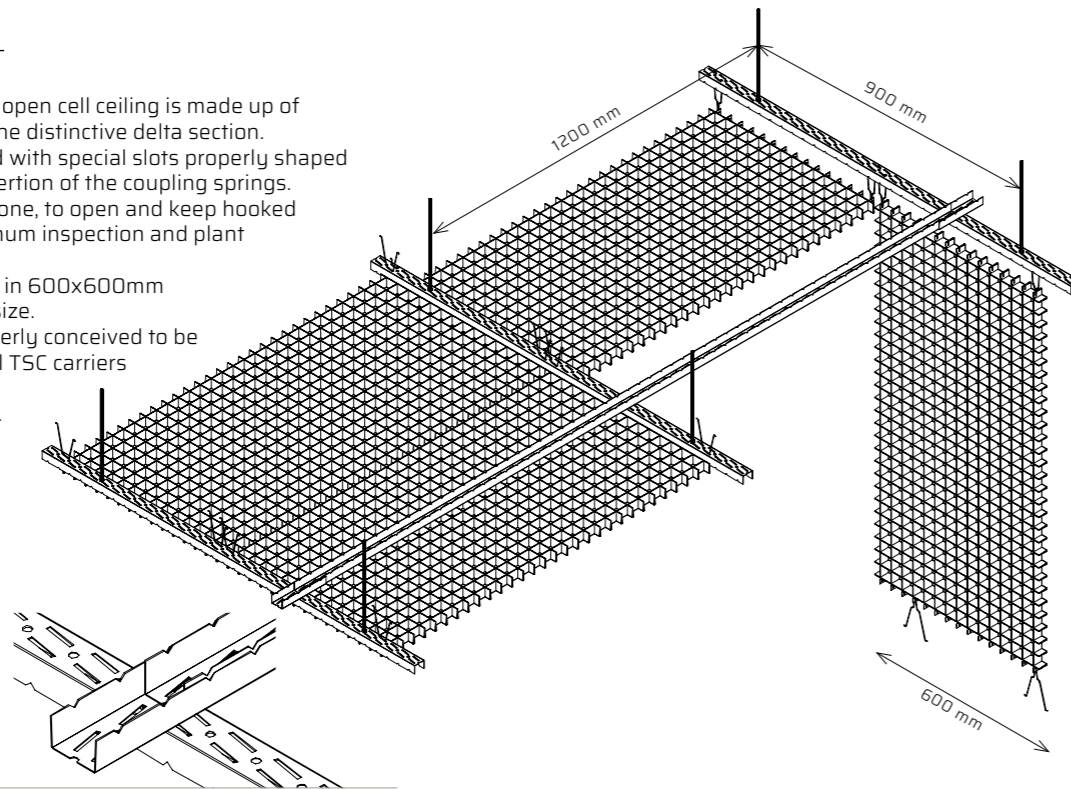

FEATURES

PRODUCT TYPE

600x600 | 600x1200 mm open cell panels
other modules on request

OPEN CELL ELEMENTS

Base 4 H30 interlocking TM-TF profiles

MATERIALS

4/10 Aluminum

INTEGRATED STRUCTURE

Carriers/spacers 27x33x27 L=2400 mm
in 8/10 black prepainted steel
Wire steel hooking springs

HANGERS*

Threaded bar

COLORS | FINISHING

Atena standard white and silver pre-painted aluminum
RAL / NCS post-painting
Wood finishing on request (see page 40)

WALL ANGLES

"C" 18x33x25 mm
5/10 aluminum with the same material and finishing of the open cell

ACCESSORIES

Lighting adapters, carriers and spacers joints

OPEN CELL SECTIONS

BASE 4 H30 SC



TSC CARRIER/SPACER

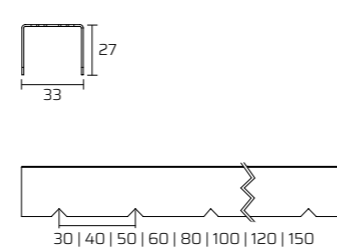

ELEMENTS SECTION

TF ELEMENTS

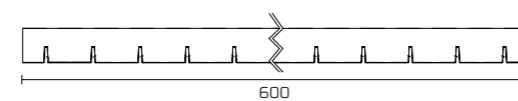

TM ELEMENTS

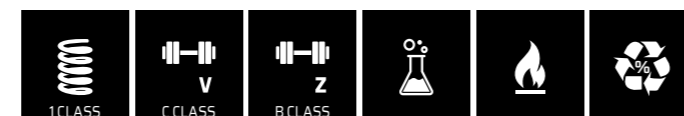
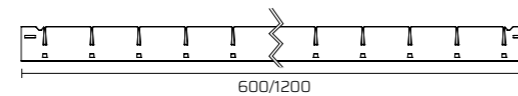

PANELS

The BASE 4 H30 SC open cell ceiling with continuous design and swinging modules is available with both standardized meshes and custom made cells, on request.

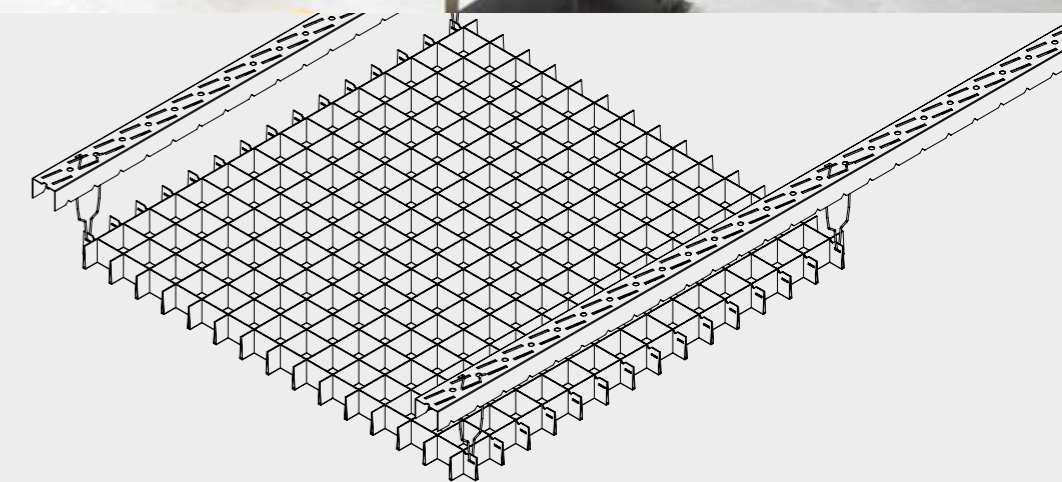

TECHNICAL FEATURES

MODEL*	SQUARE MESHES	OPEN AREA	600x600 PANEL ELEMENT QUANTITY				CARRIER					SYSTEM	
			TM 600 mm	TF 600 mm	LM/SQM	KG/SQM	MODEL	PITCH mm	600 mm		2400 mm		
								LM/SQM	KG/SQM**	LM/SQM	KG/SQM**	KG/SQM	
BASE 4 H30 SC 600x600 mm	40x40	81%	15	15	50,00	3,41	TSC40	40	1,70	0,88	0,42	0,22	4,80
	50x50	85%	12	12	40,00	2,73	TSC50	50	1,70	0,88	0,42	0,22	4,12
	60x60	87%	10	10	33,33	2,27	TSC30	60	1,70	0,88	0,42	0,22	3,67
	100x100	92%	6	6	20,00	1,36	TSC50	100	1,70	0,88	0,42	0,22	2,76
	120x120	93%	5	5	16,67	1,14	TSC30 TSC40	120	1,70	0,88	0,42	0,22	2,53
150x150	95%	4	4	13,33	0,91	TSC30 TSC50	150	1,70	0,88	0,42	0,22	2,30	
MODEL*	SQUARE MESHES	OPEN AREA	600x1200 PANEL ELEMENT QUANTITY				CARRIER					SYSTEM	
			TM 1200 mm	TF 600 mm	LM/SQM	KG/SQM	MODEL	PITCH mm	1200 mm		2400 mm		
								LM/SQM	KG/SQM**	LM/SQM	KG/SQM**	KG/SQM	
BASE 4 H30 SC 600x1200 mm	40x40	81%	15	30	50,00	3,41	TSC40	40	0,85	0,44	0,42	0,22	4,22
	50x50	85%	12	24	40,00	2,73	TSC50	50	0,85	0,44	0,42	0,22	3,53
	60x60	87%	10	20	33,33	2,27	TSC30	60	0,85	0,44	0,42	0,22	3,08
	100x100	92%	6	12	20,00	1,36	TSC50	100	0,85	0,44	0,42	0,22	2,17
	120x120	93%	5	10	16,67	1,14	TSC30 TSC40	120	0,85	0,44	0,42	0,22	1,94
150x150	95%	4	8	13,33	0,91	TSC30 TSC50	150	0,85	0,44	0,42	0,22	1,72	

* Swinging side at 600 mm only. | For specific project requirements, the hanger incidence may vary. Please check with the Atena S.p.A technical department.
** The weight includes the joints and the carriers used both as profile with 600 or 1200 mm pitch (in relation to the panel size), and as spacer with 2400 mm pitch.

ATENA METAL CELLS | OPEN CELL PANELS

BASE4 H30 SC | 600x600mm

MODEL*	RECTANG. MESHES	OPEN AREA	600x600 PANEL ELEMENTS QUANTITY				CARRIER						SYSTEM	
			TM 600 mm	TF 600 mm	LM/SQM	KG/SQM	MODEL	PITCH mm	600 mm		2400 mm			KG/SQM
									LM/SQM	KG/SQM**	LM/SQM	KG/SQM**		
BASE 4 H30 SC 600x600 mm	30x60	81%	20	10	50,00	3,41	TSC30	30	1,70	0,88	0,42	0,22	4,80	
	30x100	83%	20	6	43,33	2,96	TSC30	30	1,70	0,88	0,42	0,22	4,35	
	30x120	84%	20	5	41,67	2,84	TSC30	30	1,70	0,88	0,42	0,22	4,23	
	30x150	84%	20	4	40,00	2,73	TSC30	30	1,70	0,88	0,42	0,22	4,12	
	40x100	86%	15	6	35,00	2,39	TSC40	40	1,70	0,88	0,42	0,22	3,78	
	40x120	87%	15	5	33,33	2,27	TSC40	40	1,70	0,88	0,42	0,22	3,67	
	40x150	88%	15	4	31,67	2,16	TSC40	40	1,70	0,88	0,42	0,22	3,55	
	50x100	88%	12	6	30,00	2,05	TSC50	50	1,70	0,88	0,42	0,22	3,44	
	50x120	89%	12	5	28,33	1,93	TSC50	50	1,70	0,88	0,42	0,22	3,32	
	50x150	90%	12	4	26,67	1,82	TSC50	50	1,70	0,88	0,42	0,22	3,21	
	60x40	86%	10	12	36,67	2,50	TSC30	60	1,70	0,88	0,42	0,22	3,89	
	60x100	90%	10	6	26,67	1,82	TSC30	60	1,70	0,88	0,42	0,22	3,21	
	60x120	90%	10	5	25,00	1,71	TSC30	60	1,70	0,88	0,42	0,22	3,10	
	60x150	91%	10	4	23,33	1,59	TSC30	60	1,70	0,88	0,42	0,22	2,98	
	100x40	86%	6	15	35,00	2,39	TSC50	100	1,70	0,88	0,42	0,22	3,78	
	100x50	88%	6	12	30,00	2,05	TSC50	100	1,70	0,88	0,42	0,22	3,44	
	100x60	90%	6	10	26,67	1,82	TSC50	100	1,70	0,88	0,42	0,22	3,21	
	100x150	93%	6	4	16,67	1,14	TSC50	100	1,70	0,88	0,42	0,22	2,53	
	120x40	87%	5	15	33,33	2,27	TSC30 TSC40	120	1,70	0,88	0,42	0,22	3,67	
	120x50	89%	5	12	28,33	1,93	TSC30 TSC40	120	1,70	0,88	0,42	0,22	3,32	
120x60	90%	5	10	25,00	1,71	TSC30 TSC40	120	1,70	0,88	0,42	0,22	3,10		
150x40	88%	4	15	31,67	2,16	TSC30 TSC50	150	1,70	0,88	0,42	0,22	3,55		
150x50	90%	4	12	26,67	1,82	TSC30 TSC50	150	1,70	0,88	0,42	0,22	3,21		
150x60	91%	4	10	23,33	1,59	TSC30 TSC50	150	1,70	0,88	0,42	0,22	2,98		

* Swinging side at 600 mm only. | For specific project requirements, the hanger incidence may vary. Please check with the Atena S.p.A technical department.
 ** The weight includes the joints and the carriers used both as profile with 600 or 1200 mm pitch (in relation to the panel size), and as spacer with 2400 mm pitch.

BASE4 H30 SC | 600x1200mm

MODEL*	RECTANG. MESHES	OPEN AREA	600x1200 PANEL ELEMENTS QUANTITY				CARRIER						SYSTEM	
			TM 1200 mm	TF 600 mm	LM/SQM	KG/SQM	MODEL	PITCH mm	1200 mm		2400 mm			KG/SQM
									LM/SQM	KG/SQM**	LM/SQM	KG/SQM**		
BASE 4 H30 SC 600x1200 mm	30x60	81%	20	20	50,00	3,41	TSC30	30	0,85	0,44	0,42	0,22	4,22	
	30x100	83%	20	12	43,33	2,96	TSC30	30	0,85	0,44	0,42	0,22	3,76	
	30x120	84%	20	10	41,67	2,84	TSC30	30	0,85	0,44	0,42	0,22	3,65	
	30x150	84%	20	8	40,00	2,73	TSC30	30	0,85	0,44	0,42	0,22	3,53	
	40x100	86%	15	12	35,00	2,39	TSC40	40	0,85	0,44	0,42	0,22	3,19	
	40x120	87%	15	10	33,33	2,27	TSC40	40	0,85	0,44	0,42	0,22	3,08	
	40x150	88%	15	8	31,67	2,16	TSC40	40	0,85	0,44	0,42	0,22	2,97	
	50x100	88%	12	12	30,00	2,05	TSC50	50	0,85	0,44	0,42	0,22	2,85	
	50x120	89%	12	10	28,33	1,93	TSC50	50	0,85	0,44	0,42	0,22	2,74	
	50x150	90%	12	8	26,67	1,82	TSC50	50	0,85	0,44	0,42	0,22	2,62	
	60x40	84%	10	30	41,67	2,84	TSC30	60	0,85	0,44	0,42	0,22	3,65	
	60x100	90%	10	12	26,67	1,82	TSC30	60	0,85	0,44	0,42	0,22	2,62	
	60x120	90%	10	10	25,00	1,71	TSC30	60	0,85	0,44	0,42	0,22	2,51	
	60x150	91%	10	8	23,33	1,59	TSC30	60	0,85	0,44	0,42	0,22	2,40	
	80x40	86%	7,5	30	37,50	2,56	TSC40	80	0,85	0,44	0,42	0,22	3,36	
	80x50	87%	7,5	24	32,50	2,22	TSC40	80	0,85	0,44	0,42	0,22	3,02	
	80x120	92%	7,5	10	20,83	1,42	TSC40	80	0,85	0,44	0,42	0,22	2,23	
	80x150	92%	7,5	8	19,17	1,31	TSC40	80	0,85	0,44	0,42	0,22	2,11	
	100x40	86%	6	30	35,00	2,39	TSC50	100	0,85	0,44	0,42	0,22	3,19	
	100x50	88%	6	24	30,00	2,05	TSC50	100	0,85	0,44	0,42	0,22	2,85	
	100x60	90%	6	20	26,67	1,82	TSC50	100	0,85	0,44	0,42	0,22	2,62	
	120x40	87%	5	30	33,33	2,27	TSC30 TSC40	120	0,85	0,44	0,42	0,22	3,08	
	120x50	89%	5	24	28,33	1,93	TSC30 TSC40	120	0,85	0,44	0,42	0,22	2,74	
	120x60	90%	5	20	25,00	1,71	TSC30 TSC40	120	0,85	0,44	0,42	0,22	2,51	
	150x40	88%	4	30	31,67	2,16	TSC30 TSC50	150	0,85	0,44	0,42	0,22	2,97	
	150x50	90%	4	24	26,67	1,82	TSC30 TSC50	150	0,85	0,44	0,42	0,22	2,62	
	150x60	91%	4	20	23,33	1,59	TSC30 TSC50	150	0,85	0,44	0,42	0,22	2,40	

* Swinging side at 600 mm only. | For specific project requirements, the hanger incidence may vary. Please check with the Atena S.p.A technical department.
 ** The weight includes the joints and the carriers used both as profile with 600 or 1200 mm pitch (in relation to the panel size), and as spacer with 2400 mm pitch.



ATENA METAL CELLS | OPEN CELL PANELS

BASE 4 H30 SC DUALGRID

The DUALGRID version of the BASE 4 H30 SC open cell stands out for the difference in level between the compositional elements. Therefore, the closed blades with 4 mm base, are inserted on the "C" elements, keeping the distinctive 12 mm lowering.

At their ends the blades are equipped with special slots properly shaped to allow an easy insertion of the coupling springs.

Panels, in fact, available in 600x1200mm size, are properly conceived to be hooked up to special TSC carriers with pitched cuts for blades centering.

To assure correct alignment of the carriers, they will be used as spacers to be installed orthogonally at an interaxe of 2400 mm.

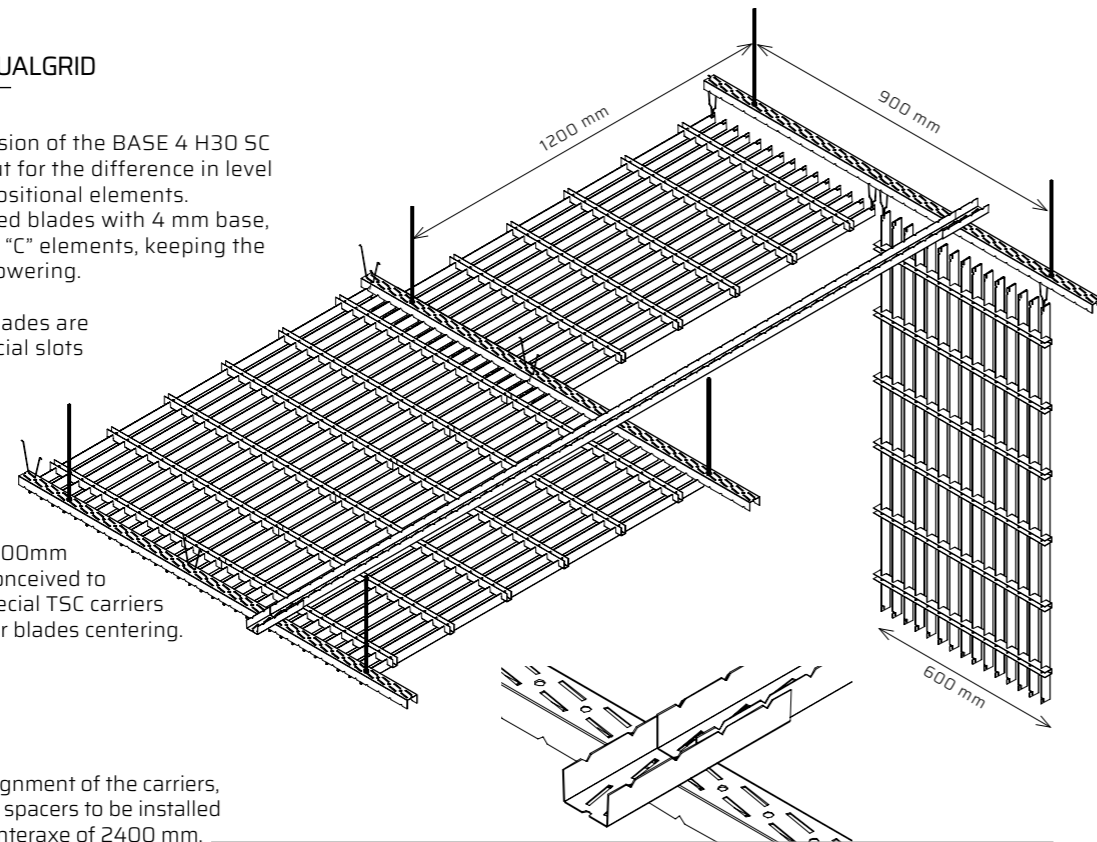

FEATURES

PRODUCT TYPE

600x1200 mm open cell panels
other modules on request

OPEN CELL ELEMENTS

Base 4 H30 TM-TF interlocking profiles

MATERIALS

4/10 Aluminum

INTEGRATED STRUCTURE

Carriers/spacers 27x33x27 L=2400 mm
in 8/10 black prepainted steel
Wire steel hooking springs

HANGERS

M6 threaded bar

COLORS | FINISHING

Atena standard white and silver pre-painted aluminum
RAL / NCS post-painting
Wood finishing on request (see page 40)

WALL ANGLES

"C" 18x33x25 mm
5/10 aluminum with the same material and finishing of the open cell

ACCESSORIES

Lighting adapters, carriers and spacers joints

OPEN CELL SECTIONS

BASE 4 H30 SC DUALGRID

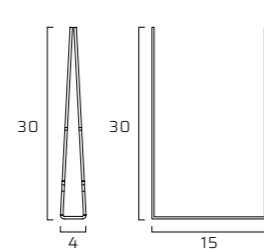

TSC CARRIER/SPACER

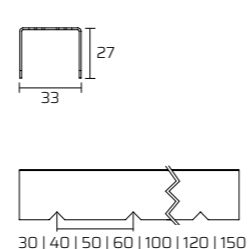

ELEMENTS SECTION

TF ELEMENTS

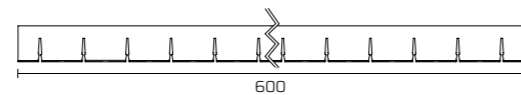

TM ELEMENTS

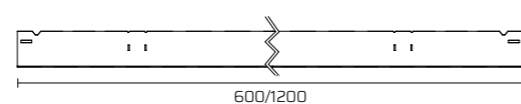

PANELS

The BASE 4 H30 SC DUALGRID open cell ceiling with continuous design and swinging modules is available with both standardized meshes and custom made cells, on request.

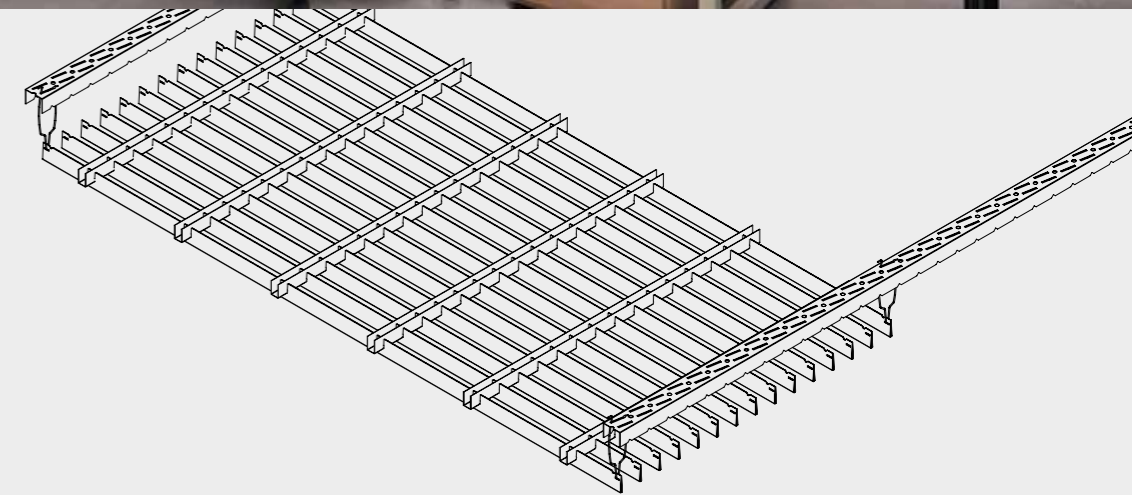

TECHNICAL FEATURES

MODEL*	RECTANG. MESHES	OPEN AREA	600x1200 PANEL ELEMENTS QUANTITY				CARRIER						SYSTEM
			TM 600 mm	TF 600 mm	LM/SQM	KG/SQM	MODEL	PITCH mm	1200 mm		2400 mm		
									LM/SQM	KG/SQM**	LM/SQM	KG/SQM**	
BASE 4 H30 SC DUALGRID	30x180	79,44%	20	6	76,67	5,81	TSC30	30	0,85	0,44	0,42	0,22	6,62
	30x270	81,85%	20	4	73,33	5,59	TSC30	30	0,85	0,44	0,42	0,22	6,39
	40x180	82,50%	15	6	60,00	4,68	TSC40	40	0,85	0,44	0,42	0,22	5,48
	40x270	85,00%	15	4	56,67	4,45	TSC40	30	0,85	0,44	0,42	0,22	5,26
	50x180	84,33%	12	6	50,00	4,00	TSC50	50	0,85	0,44	0,42	0,22	4,80
	50x270	86,89%	12	4	46,67	3,77	TSC50	50	0,85	0,44	0,42	0,22	4,57
	60x180	85,56%	10	6	43,33	3,54	TSC30	60	0,85	0,44	0,42	0,22	4,35
	60x270	88,15%	10	4	40,00	3,31	TSC30	60	0,85	0,44	0,42	0,22	4,12
	100x180	88,00%	6	6	30,00	2,63	TSC50	100	0,85	0,44	0,42	0,22	3,44
	100x270	90,67%	6	4	26,67	2,40	TSC50	100	0,85	0,44	0,42	0,22	3,21
	120x180	88,61%	5	6	26,67	2,40	TSC30 TSC40	120	0,85	0,44	0,42	0,22	3,21
	120x270	91,30%	5	4	23,33	2,18	TSC30 TSC40	120	0,85	0,44	0,42	0,22	2,98
	150x180	89,22%	4	6	23,33	2,18	TSC30 TSC50	150	0,85	0,44	0,42	0,22	2,98
	150x270	91,93%	4	4	20,00	1,95	TSC30 TSC50	150	0,85	0,44	0,42	0,22	2,76

* Swinging side at 600 mm only. | For specific project requirements, the hanger incidence may vary. Please check with the Atena S.p.A technical department.
** The weight includes the joints and the carriers used both as profile with 600 or 1200 mm pitch (in relation to the panel size), and as spacer with 2400 mm pitch.



BASE 4 H18 | H30

Atena BASE 4 is a smart and original solution to create a uniform and plain metal ceiling in which the main elements are mixed up with the carriers without any junction.

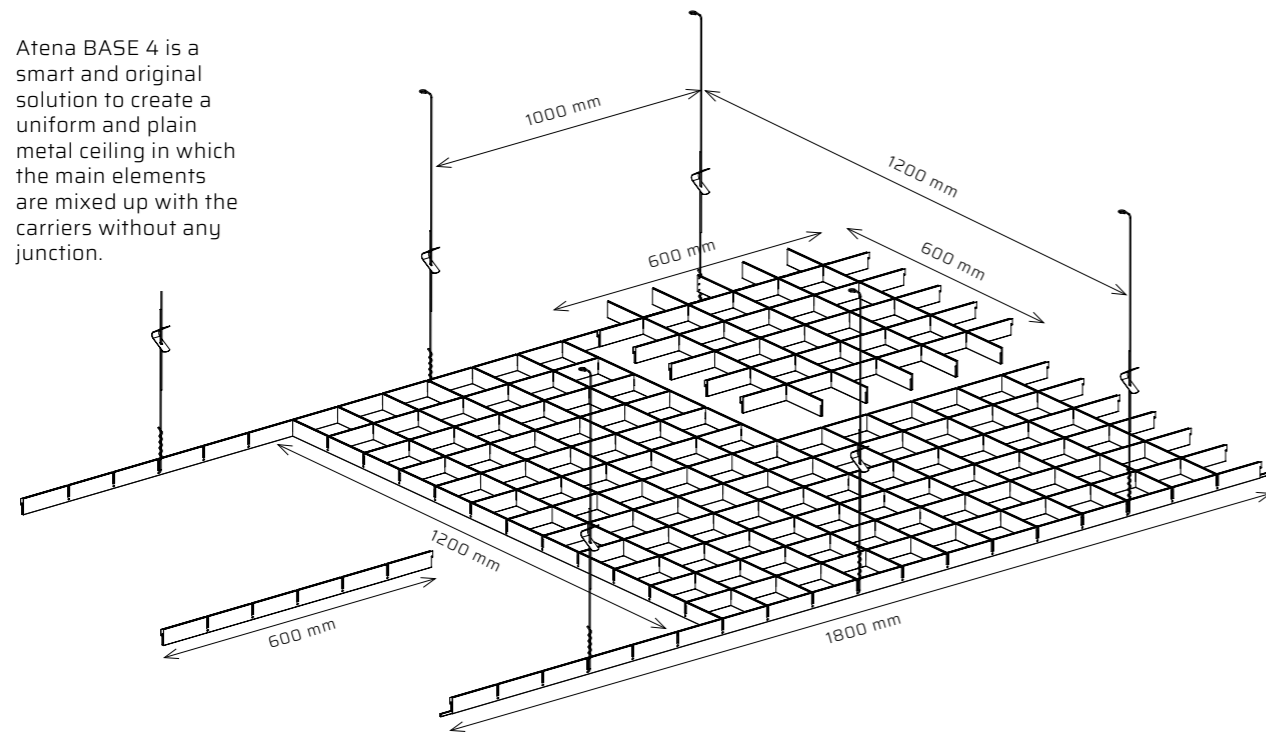

FEATURES

PRODUCT TYPE

600x600 mm open cell panels
other modules on request

OPEN CELL ELEMENTS

Base 4 H18 | base 4 H30 TM-TF interlocking profiles

MATERIALS

4/10 Aluminum

INTEGRATED STRUCTURE

1800 mm main profiles
1200 mm cross profiles
600 mm cross profiles

HANGERS

Ø2 standard hanger with spring

COLORS | FINISHING

Atena standard white and silver pre-painted aluminum
RAL / NCS post-painting
Wood finishing on request (see page 40)

WALL ANGLES

"C" 10x20x25 mm for H18 | 18x33x25 mm for H30
with the same material and finishing of the open cell

ACCESSORIES

Lighting adapters

OPEN CELL SECTIONS

BASE 4 H18 | H30

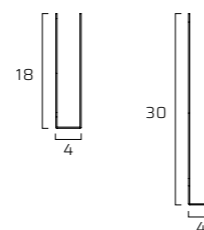

ELEMENTS SECTION

TF ELEMENTS

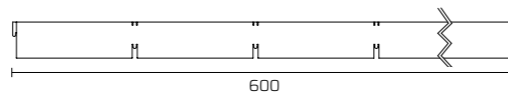

TM AND MAIN ELEMENTS

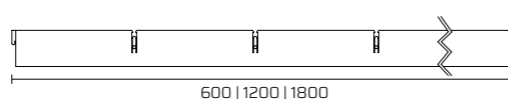

PANELS

BASE 4 open cell is made up of 600x600 mm panels composed of TM and TF elements having an "U-shaped" section with a height of 18 or 30 mm and a base of 4 mm. These elements cross each other to realize the desired mesh and they are installed with an integrated bearing structure made of the same material.

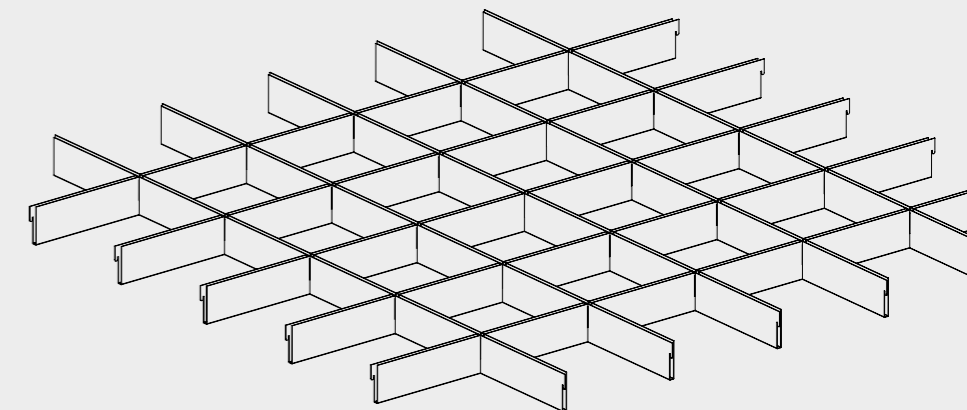

TECHNICAL FEATURES

MODEL	MESHES	OPEN AREA	600x600 PANEL ELEMENTS QUANTITY		PIECES/SQM			LM/SQM	KG/SQM	
			TM 600 mm	TF 600 mm	1800 mm PROFILE	1200 mm PROFILE	600 mm PROFILE		H18	H30
BASE 4 H18	20x20	64%	29	29	0,93	-	2,78	100,00	4,3	6,8
	30x30	75,1%	19	19	0,93	-	2,78	66,66	2,9	4,7
	40x40	81%	14	14	0,93	-	2,78	50,00	2,2	3,6
BASE 4 H30	50x50	84,6%	11	11	0,93	-	2,78	40,00	1,7	2,7
	60x60	87,1%	9	9	0,93	-	2,78	33,33	1,4	2,3
	75x75	89,6%	7	7	0,46	1,38	1,38	26,66	1,1	1,8

For specific project requirements, the hanger incidence may vary. Please check with the Atena S.p.A technical department.

ATENA METAL CELLS | OPEN CELL PANELS

BASE 4 T15 | T24

Easy to install BASE 4 panels can be simply laid on T24 and T15 visible structure, to create smart metal ceilings.

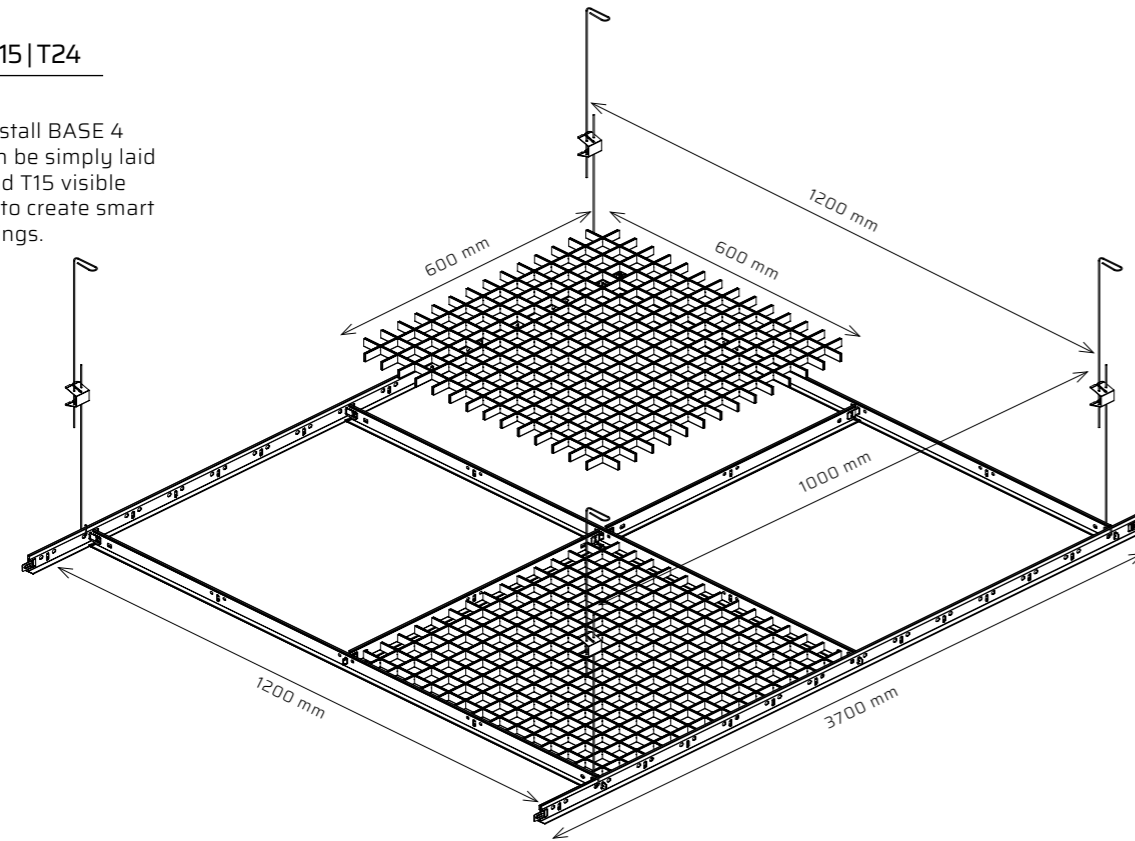

FEATURES

PRODUCT TYPE

600x600 | 600x1200 mm open cell panels
other modules on request

OPEN CELL ELEMENTS

Base 4 H18 | base 4 H30 TM-TF interlocking profiles

MATERIALS

4/10 Aluminum

INTEGRATED STRUCTURE ATENA STEEL STRONG

Main T15 | T24 da 3700 mm Easy T15
Cross T15 | T24 da 1200 mm Easy T24 | Easy Fox
Cross T15 | T24 da 600 mm Easy T24 Antiseismic

HANGERS*

Twister, Nonius, Standard with spring, 90° hanger

COLORS | FINISHING

Atena standard white and silver pre-painted aluminum
RAL / NCS post-painting
Wood finishing on request (see page 40)

WALL ANGLES

"C" 25x42x10 mm
with the same material and finishing of the open cell

ACCESSORIES

Lighting adapters | Antiseismic Kit on request

OPEN CELL SECTIONS

BASE 4 T15 | T24

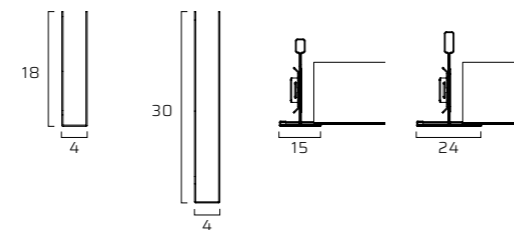

ELEMENTS SECTION

TF ELEMENTS

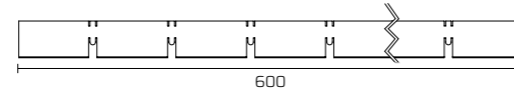

TM ELEMENTS

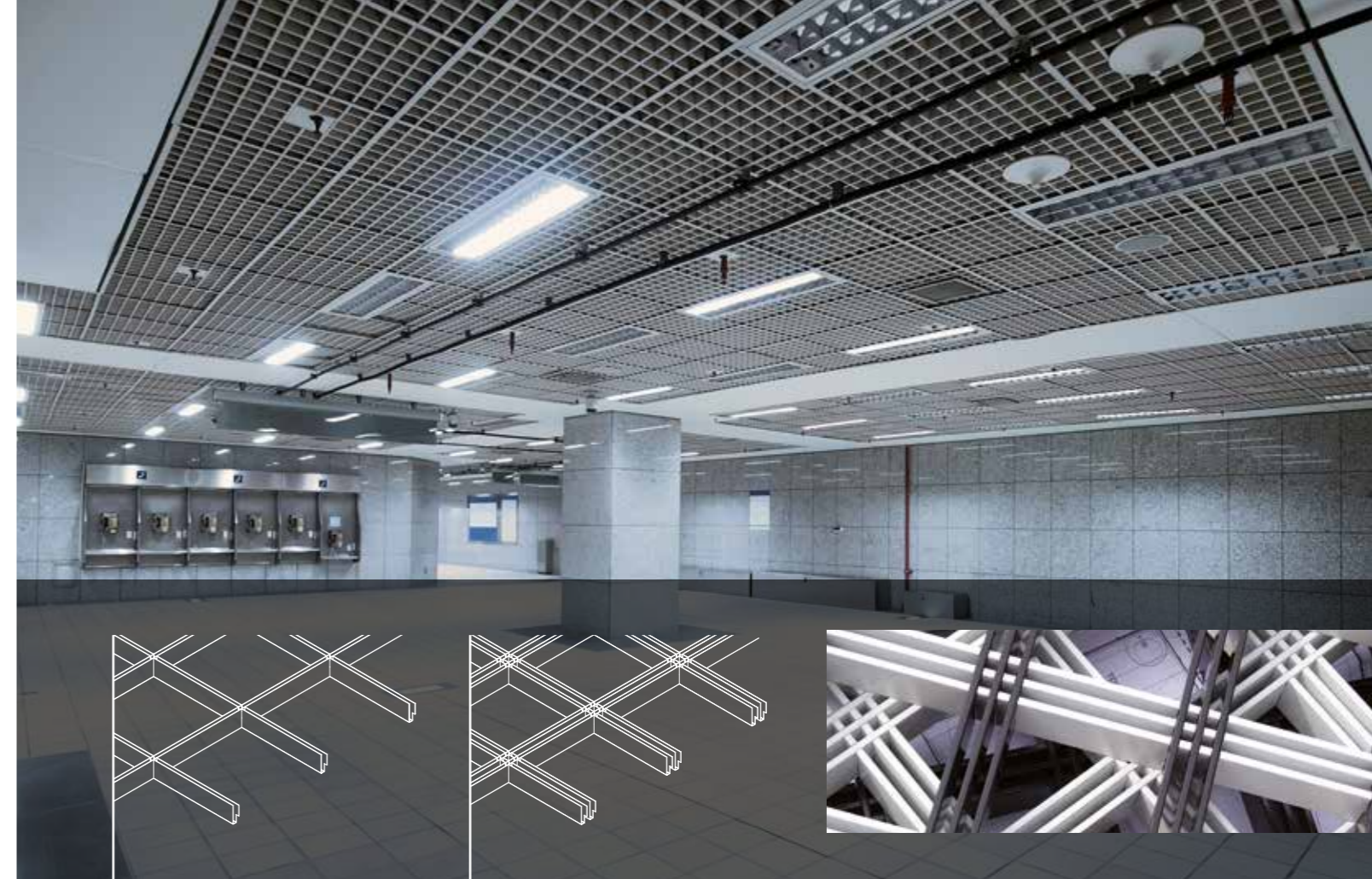
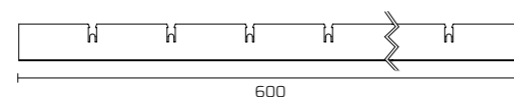

PANELS

BASE 4 open cell can be also realized installing the panels on Atena Steel Strong visible structures T24 and T15.

ORIGINAL MIX!

Base 4 is available in different models made up of one or more elements on request.

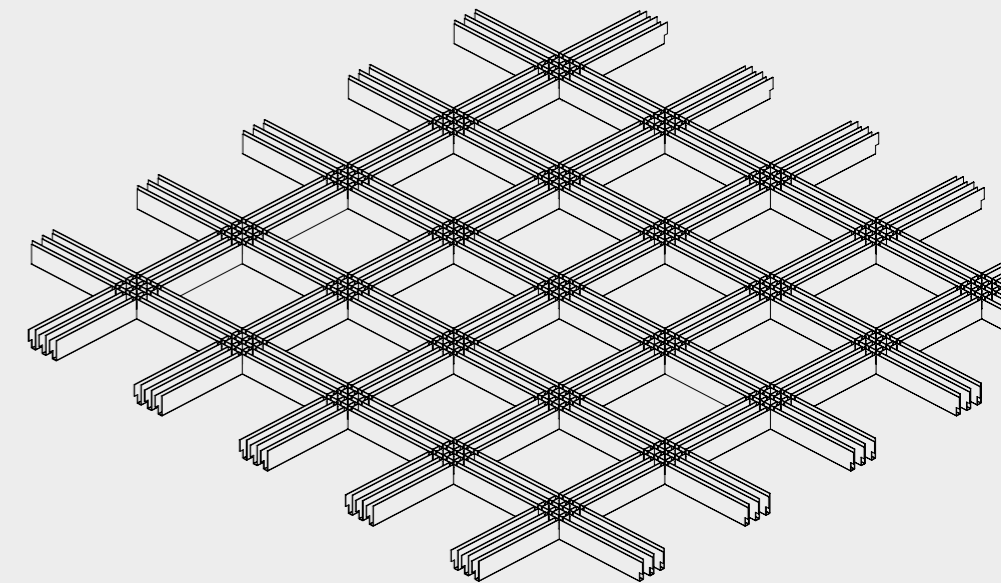

TECHNICAL FEATURES

MODEL	MESHES	OPEN AREA	600x600 PANEL ELEMENTS QUANTITY		LM/SQM	KG/SQM	
			TM 600 mm	TF 600 mm		H18	H30
BASE 4 T15 T24	20x20	64%	29	29	96,67	4,1	6,6
	30x30	75,1%	19	19	63,33	2,7	4,4
	40x40	81%	14	14	46,67	2,0	3,2
	50x50	84,6%	11	11	36,67	1,6	2,6
	60x60	87,1%	9	9	30,00	1,3	2,1
	75x75	89,6%	7	7	23,33	1,0	1,6

For specific project requirements, the hanger incidence may vary. Please check with the Atena S.p.A technical department.

BASE 4 EASY LINE

BASE 4 open cell panels can be laid on Easy Line visible structure: an original system conceived to create an innovative lay-out.

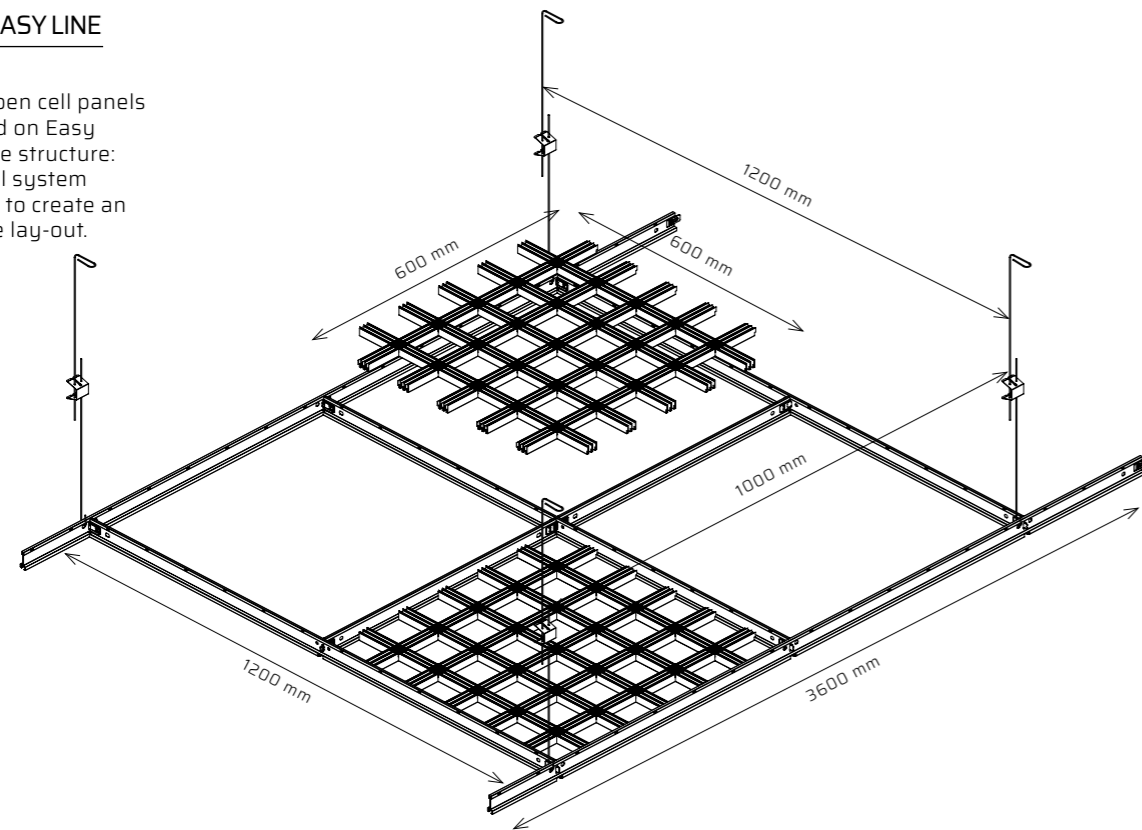

FEATURES

PRODUCT TYPE

600x600 | 600x1200 mm open cell panels
other modules on request

OPEN CELL ELEMENTS

Base 4 H18 | base 4 H30 TM-TF interlocking profiles

MATERIALS

4/10 Aluminum

INTEGRATED STRUCTURE ATENA STEEL STRONG

Main profile 3600 mm
Cross profile 1200 mm
Cross profile 600 mm

Easy Line

HANGERS*

Twister, Nonius, Standard with spring, 90° hanger

COLORS | FINISHING

Atena standard white and silver pre-painted aluminum
RAL / NCS post-painting
Wood finishing on request (see page 40)

WALL ANGLES

"C" 25x52x10 mm
with the same material and finishing of the open cell

ACCESSORIES

Lighting adapters | Antiseismic Kit on request

OPEN CELL SECTIONS

BASE 4 EASY LINE

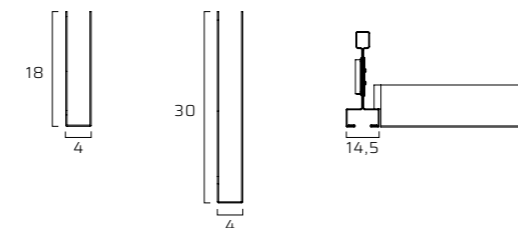

ELEMENTS SECTION

TF ELEMENTS

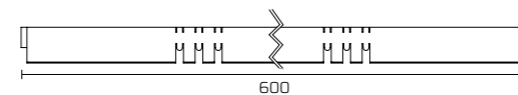

TM ELEMENTS

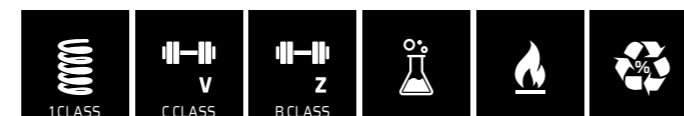
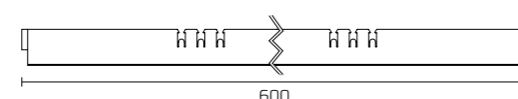

PANELS

By installing Atena Open Cell BASE 4 on Easy Line, you can create a particular colour scheme.

Tiles laid on Easy Line coloured grid are perfectly planar with it; on request, Atena offers a coloured shutter with led lighting strip, which enriches the composition.

ORIGINAL MIX!

Base 4 is available in different models made up of one or more elements on request.

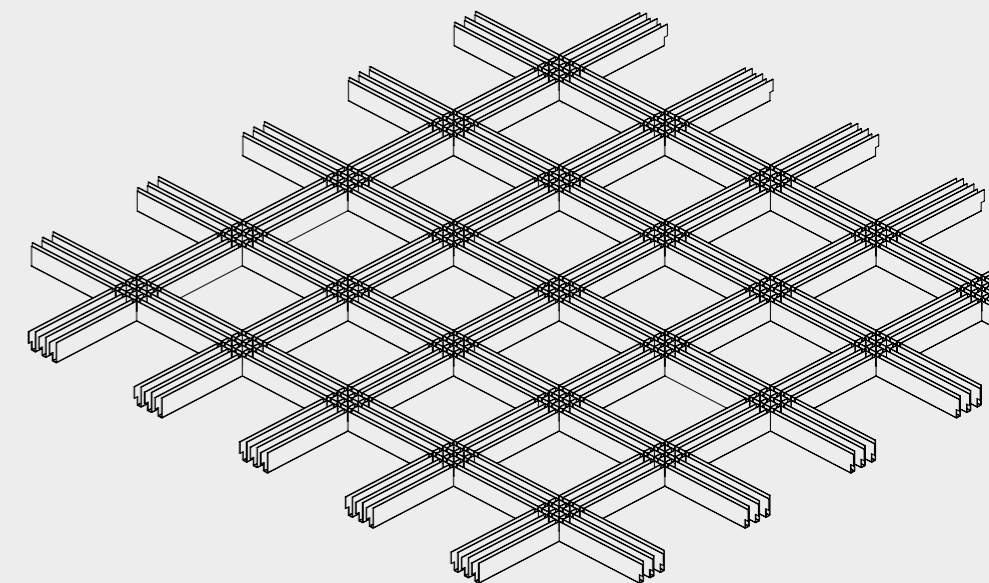

TECHNICAL FEATURES

MODEL	MESHES	OPEN AREA	600x600 PANEL ELEMENTS QUANTITY		LM/SQM	KG/SQM	
			TM 600 mm	TF 600 mm		H18	H30
BASE 4 T15 T24	20x20	64%	29	29	96,67	4,1	6,6
	30x30	75,1%	19	19	63,33	2,7	4,4
	40x40	81%	14	14	46,67	2,0	3,2
	50x50	84,6%	11	11	36,67	1,6	2,6
	60x60	87,1%	9	9	30,00	1,3	2,1
	75x75	89,6%	7	7	23,33	1,0	1,6

For specific project requirements, the hanger incidence may vary. Please check with the Atena S.p.A technical department.



ATENA METAL CELLS | OPEN CELL PANELS

BASE 20 H80

Atena Base 20 H80 OPEN CELL METAL CEILINGS have their own main structure which create an effect of continuousness without junctions or gaps among the panels.

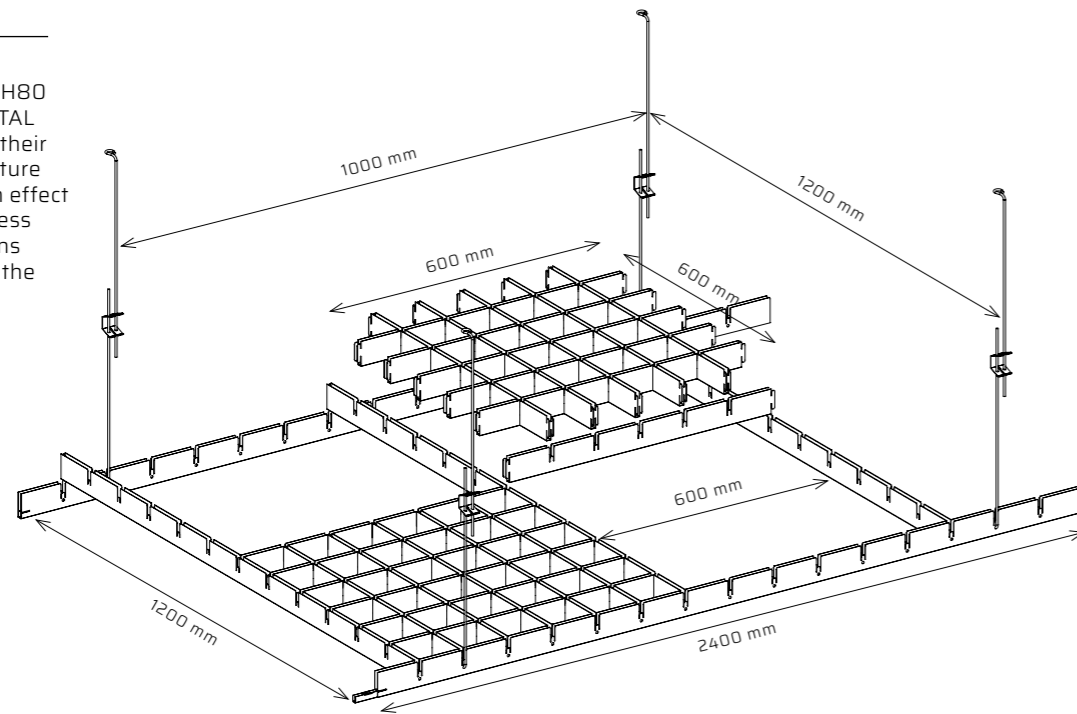

FEATURES

PRODUCT TYPE

600x600 mm open cell panels
other modules on request

OPEN CELL ELEMENTS

Base 20 H80 TM-TF interlocking profiles
Central groove on request

MATERIALS

5/10 Aluminum

INTEGRATED STRUCTURE

2400 mm main profiles
1200 mm cross profiles
600 mm cross profiles

HANGERS

Ø4 standard hanger with spring

COLORS | FINISHING

Atena standard white and silver pre-painted aluminum
RAL / NCS post-painting
Wood finishing on request (see page 40)

WALL ANGLES

"C" 25x82x10 mm
with the same material and finishing of the open cell

ACCESSORIES

Lighting adapters

OPEN CELL SECTIONS

BASE 20 H80

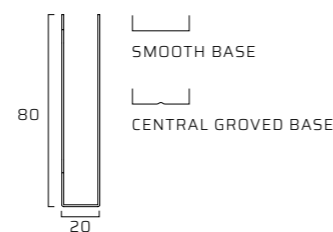

ELEMENTS SECTION

TF ELEMENTS

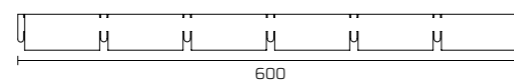

TM AND MAIN ELEMENTS

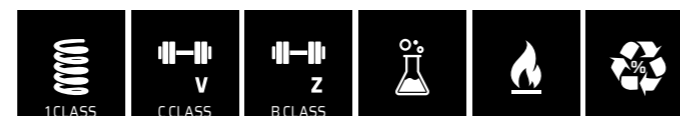
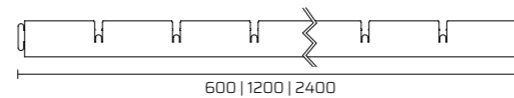

PANNELLI

The BASE 20 H80 open cell ceiling, is made up of 600x600 mm panels composed of TM and TF elements with 20 mm base and 80 mm in high.

This section gives the open cell a light and airy aesthetic, especially in the configuration with a 300x300 mm mesh, where the distance between elements, brings out the linearity of the configuration.

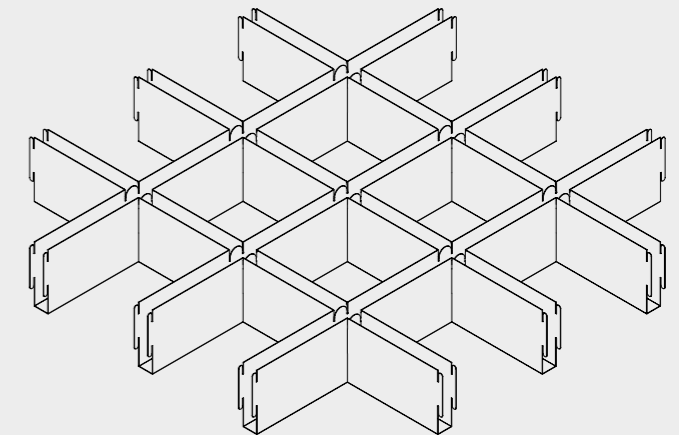

TECHNICAL FEATURES

MODEL	MESHERS	OPEN AREA	600x600 PANEL ELEMENTS QUANTITY		PIECES/SQM			LM/SQM	KG/SQM
			TM 600 mm	TF 600 mm	2400 mm PROFILE	1200 mm PROFILE	600 mm PROFILE		
BASE 20 H80	100x100	64%	5	5	0,36	1,38	1,38	20,00	4,9
	150x150	75,11%	3	3	0,36	1,38	1,38	13,33	3,3
	200x200	81%	2	2	0,36	1,38	1,38	10,00	2,5
	300x300	87,11%	1	1	0,36	1,38	1,38	6,67	1,6

For specific project requirements, the hanger incidence may vary. Please check with the Atena S.p.A technical department.



BASE 15

The open cell BASE 15 with T15 visible structure has been conceived to create linear and uniform metal ceilings. The open cell section and the structure base have, in fact, the same width.

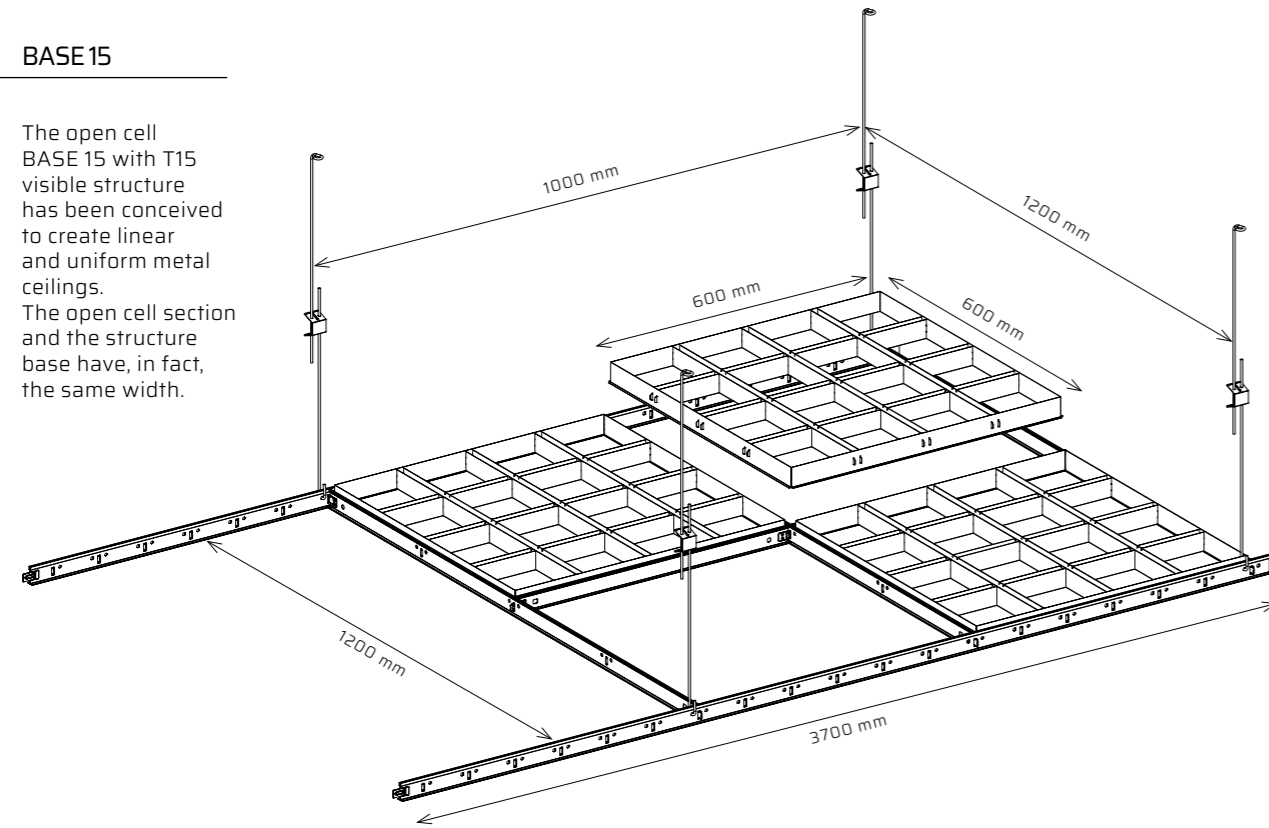

FEATURES

PRODUCT TYPE

600x600 | 600x1200 mm open cell panels
other modules on request

OPEN CELL ELEMENTS

Base 15 H37,5 TM-TF interlocking profiles

MATERIALS

5/10 Aluminum

STRUCTURE

Steel Strong Easy T15

HANGERS

Twister, Nonius, Standard with spring, 90° hanger

COLORS | FINISHING

Atena standard white and silver pre-painted aluminum
RAL / NCS post-painting
Wood finishing on request (see page 40)

WALL ANGLES

"C" 25x42x10 mm
with the same material and finishing of the open cell

ACCESSORIES

Lighting adapters

OPEN CELL SECTIONS

BASE 15

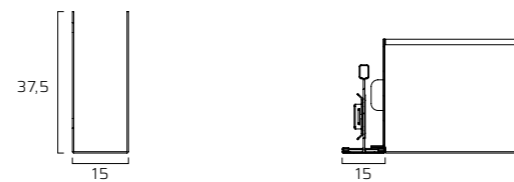

ELEMENTS SECTION

TF ELEMENTS

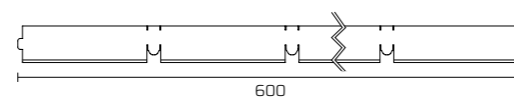

TM AND MAIN ELEMENTS



PANELS

BASE 15 metal ceiling is made up of panels composed of TM and TF elements having a "U-shaped" section with a height of 37,5 mm and a base of 15 mm. These elements cross each other to realize the desired mesh. Panels completed with their own frame lay on Atena Easy T15 visible structure.

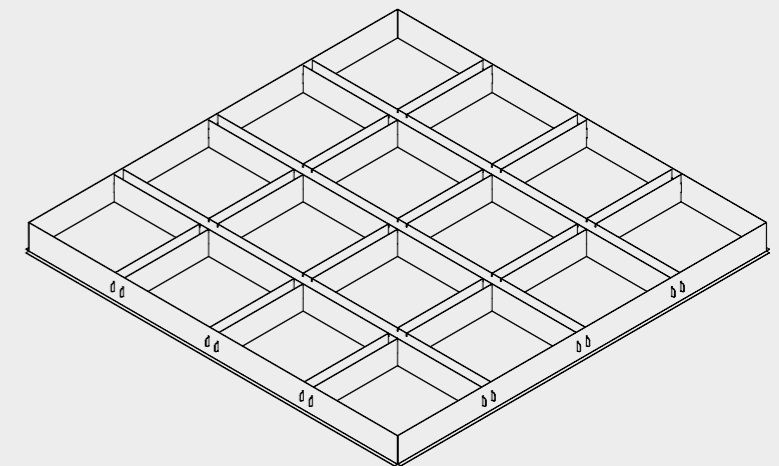

TECHNICAL FEATURES

MODEL	MESHES	OPEN AREA	600x600 PANEL ELEMENTS QUANTITY			LM/SQM	KG/SQM
			TM 600 mm	TF 600 mm	FRAME		
BASE 15	50x50	49%	11	11	4	36,66	4,7
	60x60	56,25%	9	9	4	30,00	3,9
	75x75	64%	7	7	4	23,33	3,0
	86x86	68,16%	6	6	4	20,00	2,6
	100x100	72,25%	5	5	4	16,66	2,2
	120x120	76,56%	4	4	4	13,33	1,8
	150x150	81%	3	3	4	10,00	1,4
	200x200	85,56%	2	2	4	6,66	1,0

Value describe the incidence of TM and TF, without frame.
For specific project requirements, the hanger incidence may vary. Please check with the Atena S.p.A technical department.



ATENA METAL CELLS | OPEN CELL PANELS

H40 | H50

Atena H40 and H50 open cell metal ceilings have their own main structure which create an effect of continuousness without junctions or gaps among the panels.

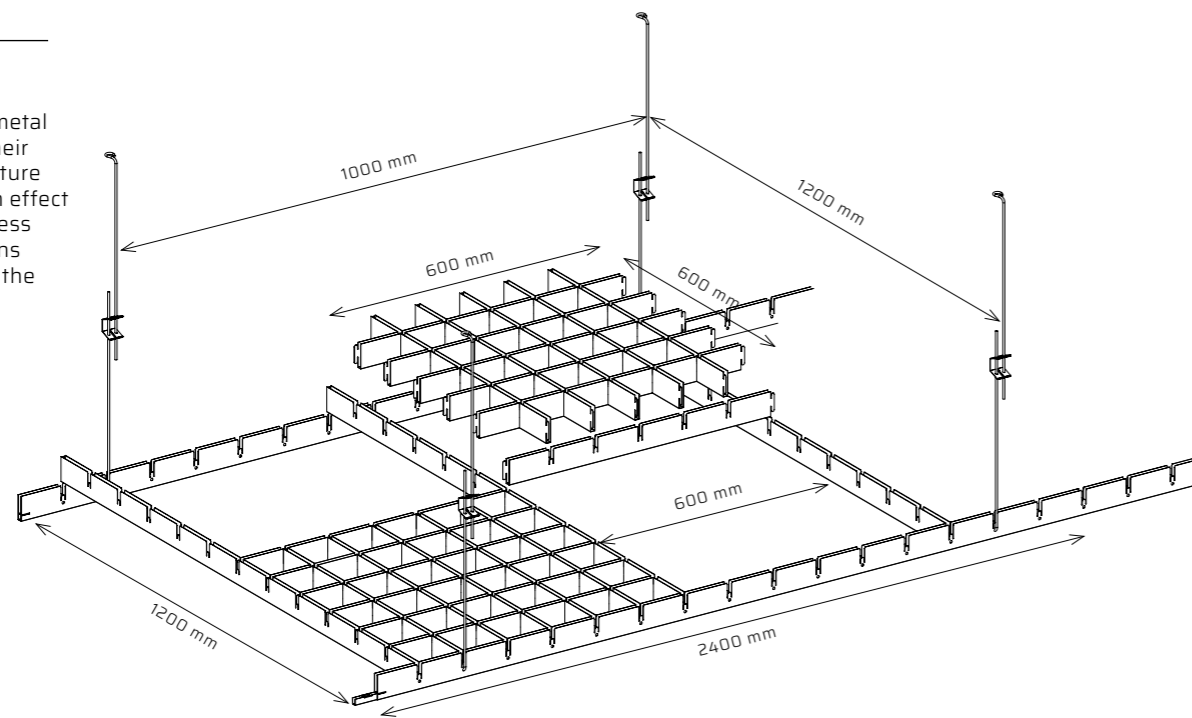

FEATURES

PRODUCT TYPE

600x600 mm open cell panels
other modules on request

OPEN CELL ELEMENTS

Base 10 H40 | base 10 H50 TM-TF interlocking profiles

MATERIALS

5/10 Aluminum

INTEGRATED STRUCTURE

2400 mm main profile
1200 mm cross profile
600 mm cross profile

HANGERS

Ø4 standard hanger with spring

COLORS | FINISHING

Atena standard white and silver pre-painted aluminum
RAL / NCS post-painting
Wood finishing on request (see page 40)

WALL ANGLES

"C" 25x42x10 mm for H40 | 25x52x10 mm for H50
with the same material and finishing of the open cell

ACCESSORIES

Lighting adapters

OPEN CELL SECTIONS

H40 | H50

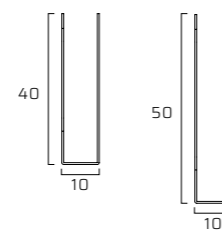

ELEMENTS SECTION

TF ELEMENTS

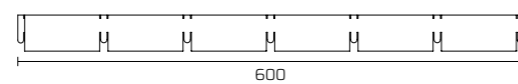

TM AND MAIN PROFILES

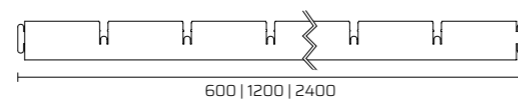

PANELS

H40 - H50 metal ceiling is made up of 600x600 mm panels composed of TM and TF elements having a U-shaped section with a height of 40 mm or 50 mm and a base of 10 mm. These elements cross each other to realize the desired mesh and are installed with an integrated bearing structure made of the same material.

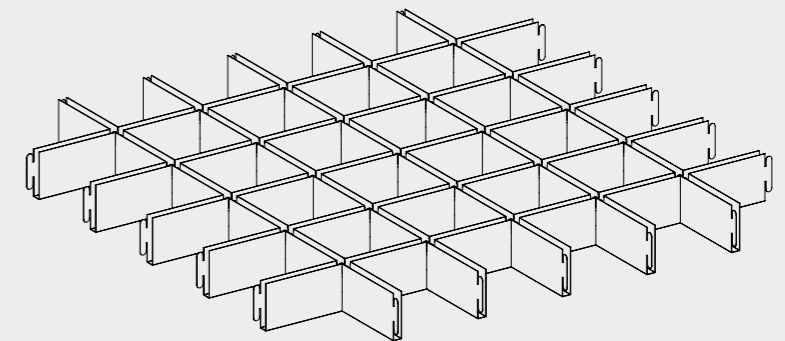

TECHNICAL FEATURES

MODEL	MESHES	OPEN AREA	600x600 PANEL ELEMENTS QUANTITY		PIECES/SQM			KG/SQM		
			TM 600 mm	TF 600 mm	2400 mm PROFILE	1200 mm PROFILE	600 mm PROFILE	LM/SQM	H40	H50
H40	50x50	64%	11	11	0,7	-	2,78	40,00	4,9	6,0
	60x60	69,44%	9	9	0,7	-	2,78	33,33	4,1	5,0
	75x75	75,11%	7	7	0,36	1,38	1,38	26,67	3,3	4,0
H50	86x86	78,1%	6	6	0,36	1,38	1,38	23,33	2,9	3,5
	100x100	81%	5	5	0,36	1,38	1,38	20,00	2,5	3,0
	120x120	84,03%	4	4	0,36	1,38	1,38	16,66	2,1	2,5
	150x150	87,1%	3	3	0,36	1,38	1,38	13,33	1,6	2,0
	200x200	90,25%	2	2	0,36	1,38	1,38	10,00	1,2	1,5

For specific project requirements, the hanger incidence may vary. Please check with the Atena S.p.A technical department.



ATENA METAL CELLS | OPEN CELL PANELS

H40 | H50 T24

Atena open cell H40 - H50 with detachment laid on T24 visible structure underlines the modular effect giving the structure a high aesthetical value.

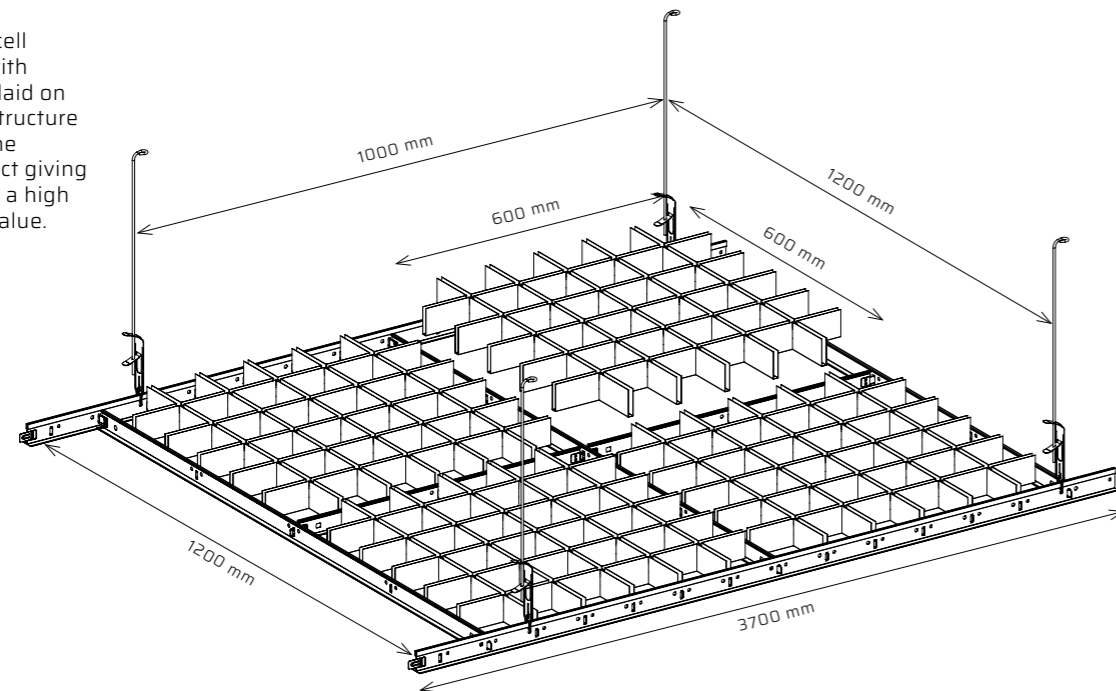

FEATURES

PRODUCT TYPE

600x600 | 600x1200 mm open cell panels
other modules on request

OPEN CELL ELEMENTS

Base 10 H40 | base 10 H50 TM-TF interlocking profiles

MATERIALS

5/10 Aluminum

INTEGRATED STRUCTURE ATENA STEEL STRONG

2400 mm main profiles Easy T24
1200 mm cross profiles Easy T24 Antiseismic
600 mm cross profiles Easy Fox

HANGERS*

Twister, Nonius, Standard with spring, 90° hanger

COLORS | FINISHING

Atena standard white and silver pre-painted aluminum
RAL / NCS post-painting
Wood finishing on request (see page 40)

WALL ANGLES

"C" 25x42x10 mm for H40 | 25x52x10 mm for H50
with the same material and finishing of the open cell

ACCESSORIES

Lighting adapters | Antiseismic Kit on request

OPEN CELL SECTIONS

H40 | H50 T24

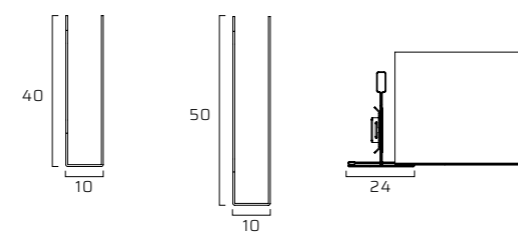

ELEMENTS SECTION

TF ELEMENTS

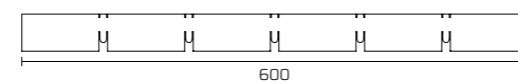

TM ELEMENTS

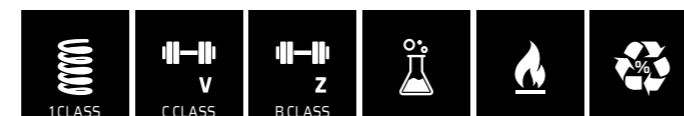
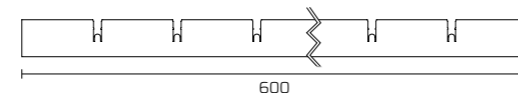

PANELS

H40 - H50 T24 metal ceiling "with detachment" is made up of panels composed of TM and TF elements having a "U-shaped" section with a height of 40 mm or 50 mm and a base of 10 mm. These elements cross each other to realize the desired mesh and they lay on the Atena Steel Strong T24 visible structures.

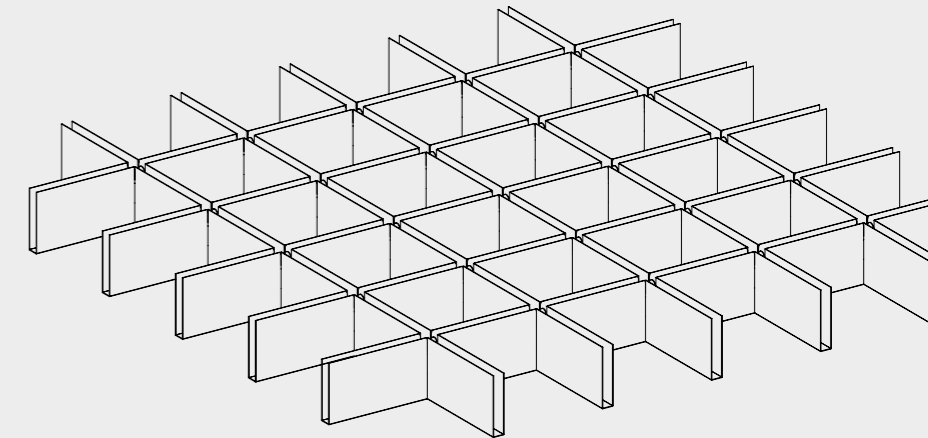

TECHNICAL FEATURES

MODEL	MESHES	OPEN AREA	600x600 PANEL ELEMENTS QUANTITY		LM/SQM	KG/SQM	
			TM 600 mm	TF 600 mm		H40	H50
H40 H50 CON STACCO	50x50	64%	11	11	36,66	4,5	5,5
	60x60	69,44%	9	9	30,00	3,7	4,5
	75x75	75,11%	7	7	23,33	2,9	3,5
	86x86	78,1%	6	6	20,00	2,5	3,0
	100x100	81%	5	5	16,66	2,1	2,5
	120x120	84,03%	4	4	13,33	1,6	2,0
	150x150	87,1%	3	3	10,00	1,2	1,5
	200x200	90,25%	2	2	6,66	0,8	1,0

For specific project requirements, the hanger incidence may vary. Please check with the Atena S.p.A technical department.

DUALGRID

DUALGRID is the modular cells system available in 600x1200 mm sizes. Its elements cross each other at different heights, creating a peculiar tri-dimensional effect.

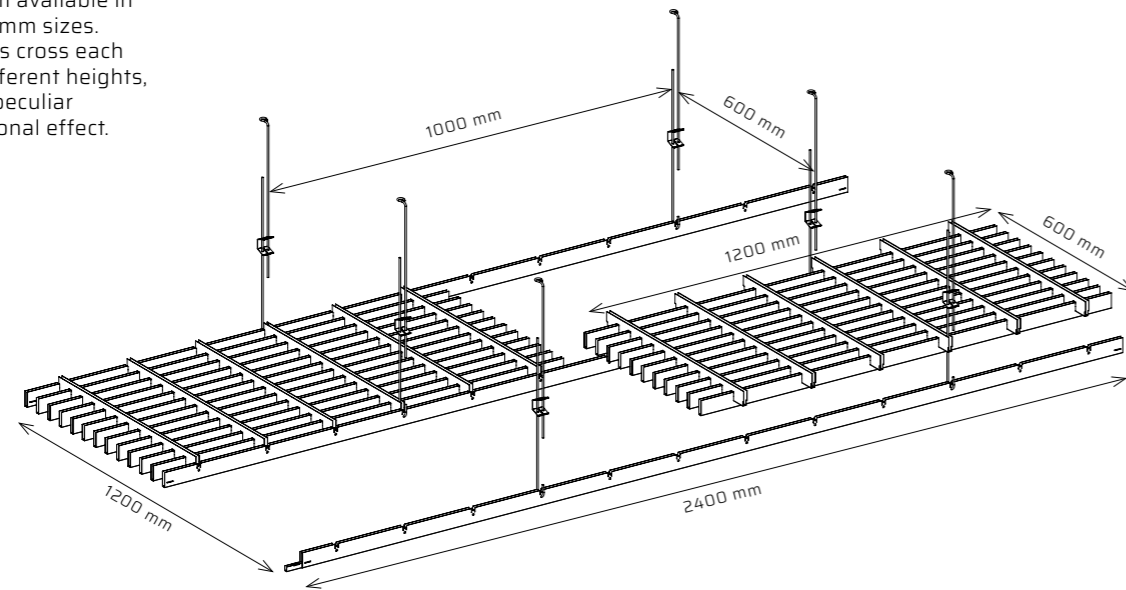

FEATURES

PRODUCT TYPE

600x1200 mm open cell panels
other modules on request

OPEN CELL ELEMENTS

Base 10 H40 TM-TF interlocking profiles

MATERIALS

5/10 Aluminum

INTEGRATED STRUCTURE

2400 mm main profiles

HANGERS

Ø4 standard hanger with spring

COLORS | FINISHING

Atena standard white and silver pre-painted aluminum
RAL / NCS post-painting
Wood finishing on request (see page 40)

WALL ANGLES

"C" 25x52x10 mm
with the same material and finishing of the open cell

ACCESSORIES

Lighting adapters

OPEN CELL SECTIONS

DUALGRID

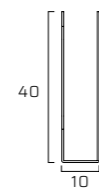

ELEMENTS SECTION

TF ELEMENTS

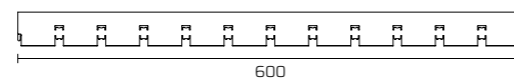

TM AND MAIN ELEMENTS

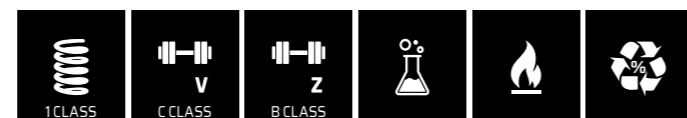
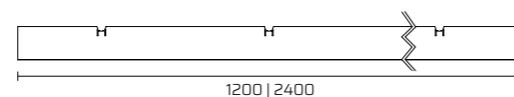

PANELS

DUALGRID metal ceiling is made up of 600x1200 mm tiles composed of TM and TF elements having a "U-shaped" section with a height of 40 mm and a base of 10 mm.

These elements cross each other to realize the desired mesh, creating a difference of 18 mm in height between the two elements. Panels are as well installed on their long side onto the bearing elements.

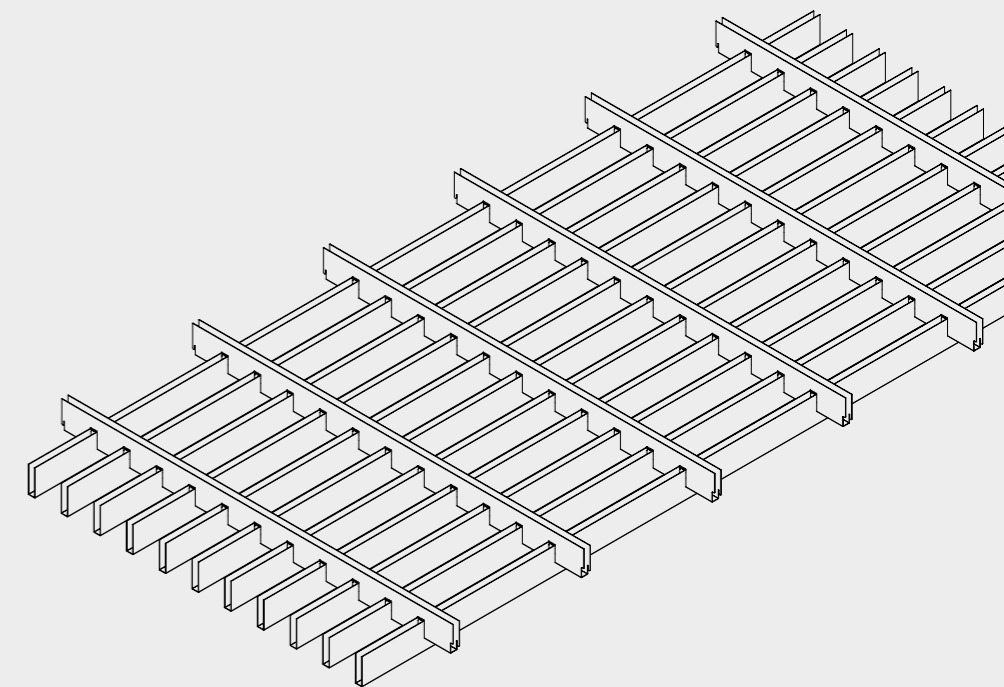

TECHNICAL FEATURES

MODEL	MESHES	OPEN AREA	600x600 PANEL ELEMENTS QUANTITY		PIECES/SQM	LM/SQM	KG/SQM
			TM 1200 mm	TF 600 mm			
DUALGRID	50x200	76%	11	6	0,7	25,03	3,1
	75x200	82,3%	7	6	0,7	18,36	2,3
	100x200	85,5%	5	6	0,7	15,03	1,9
	150x200	88,67%	3	6	0,7	11,70	1,4

For specific project requirements, the hanger incidence may vary. Please check with the Atena S.p.A technical department.



EXECUTIVE ENGINEERING

PERFORMANCES

DIMENSIONING, DESIGN FEASIBILITY

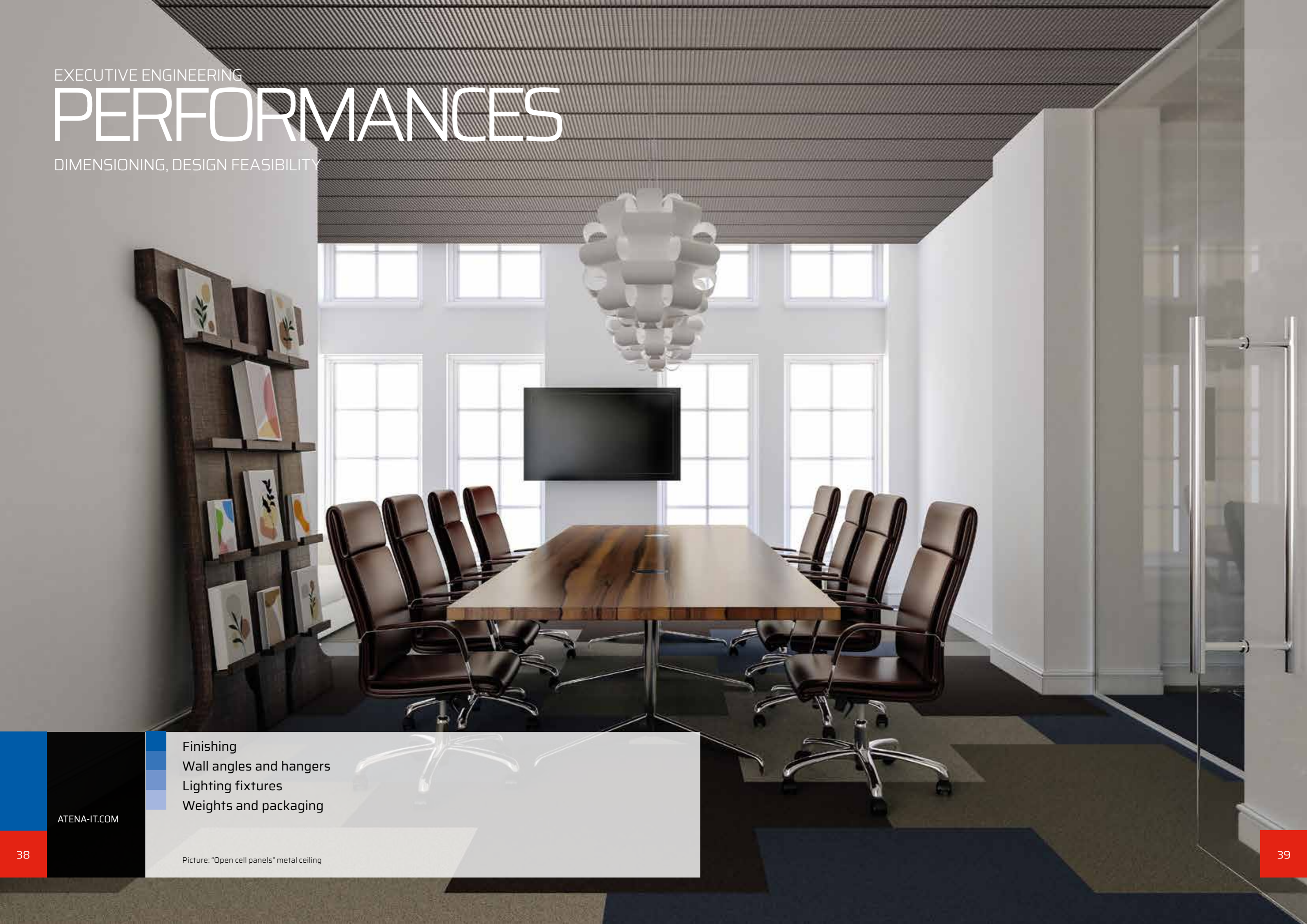

Finishing
Wall angles and hangers
Lighting fixtures
Weights and packaging

ATENA-IT.COM

Picture: "Open cell panels" metal ceiling



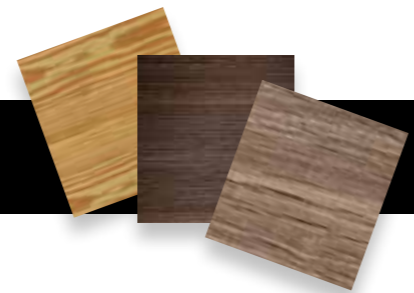

FINISHING



Metal wood effect
PVC covering
Nanotech powder coatings

The **aesthetic metal finishing** represents an important phase of the manufacturing process, and includes a wide range of **decorative techniques**, high levels of **precision in execution**, continuous research of **new materials** and **latest generation machines** to ensure high quality standards.

Standard aluminum wood

	
L07 MEDIUM PINE	L13 CHENE IRLANDAIS
	
L17 OREGON 4	L14 MADERA BRAZIL

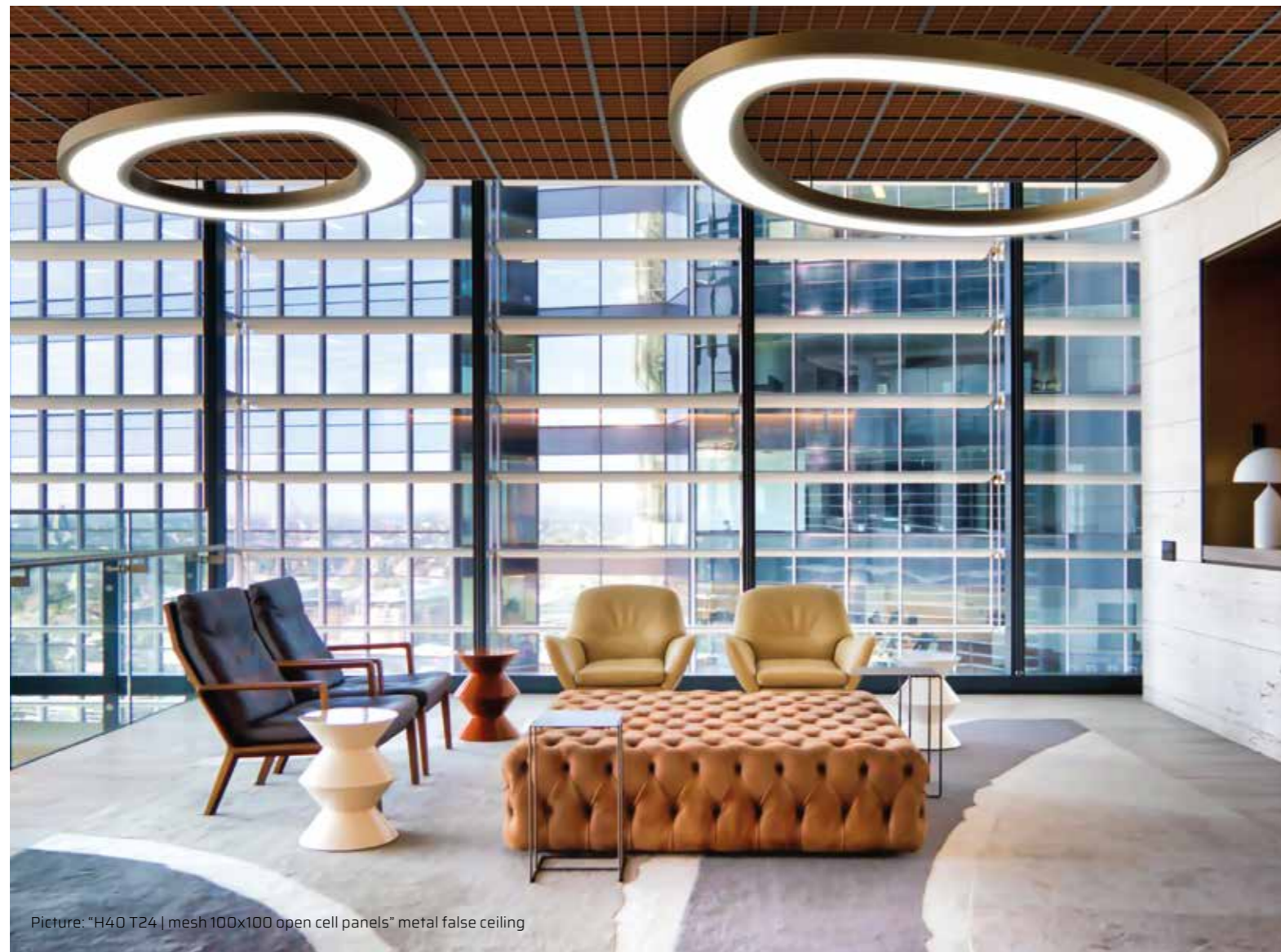

Picture: "H40 T24 | mesh 100x100 open cell panels" metal false ceiling

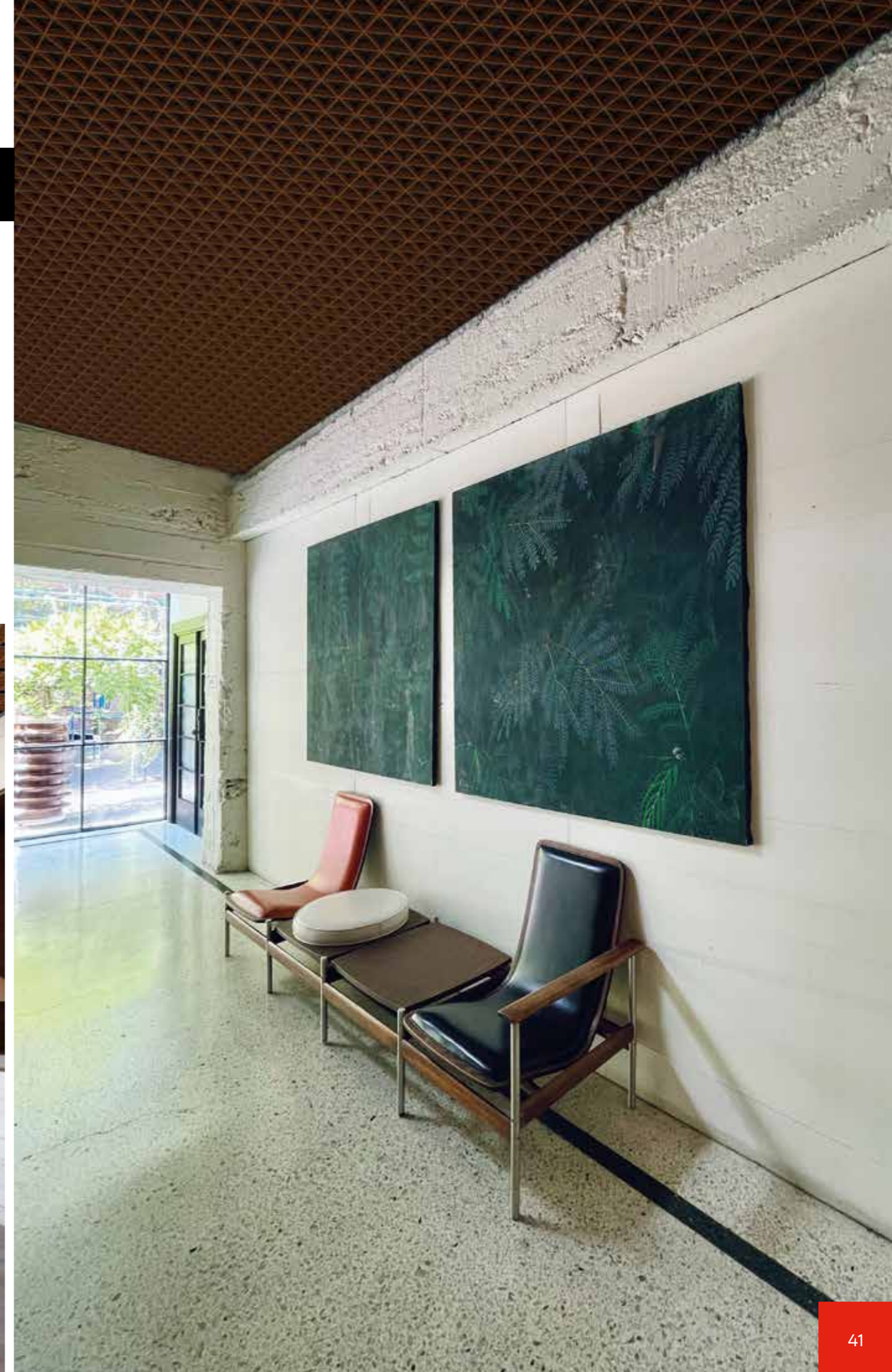

WALL ANGLES AND HANGERS

“C” AND “L” PROFILES

To frame the open cells Atena has a complete range of wall angles, supplied in the same materials and finishing of the ceiling. In addition to the standard solutions, the perimeter frame of the ceiling can be realized both with plasterboard closure and micro-perforated, smooth or sublimated metal surfaces. **According to the UNI EN 13964:2007 Atena wall angles for metal ceilings have been tested for static load by Istituto Giordano S.p.A.**

“C” 25x42x10 mm PROFILE
L=4000mm
H40 | H40 T24 | BASE 15
BASE 4 T24 | BASE 4 T15 | TRIGON



“C” 25x52x10 mm PROFILE
L=4000mm
H50 | H50 T24 | DUALGRID
BASE 4 EASY LINE



“C” 25x82x10 mm PROFILE
L=4000mm | BASE 20 H80

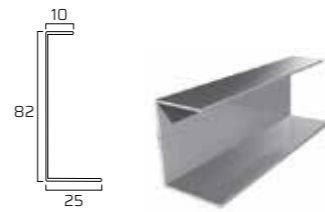

“C” 10x20x25 mm PROFILE
L=4000mm
BASE 4 H18



“C” 18x33x25 mm PROFILE
L=4000mm
BASE 4 H30 | BASE 4 H30 SC
BASE 4 H30 SC DUALGRID



“L” 55x20 mm PROFILE
L=3000mm
MONOLAMA R-T24

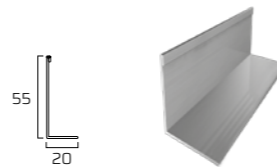

Please check with the technical department of the correct sizing of the perimeter according to the project requirements.

OPEN CELL HANGERS

Open cell with integrated structure

Ø2 mm double hanger with single spring
BASE 4 H18 | H30

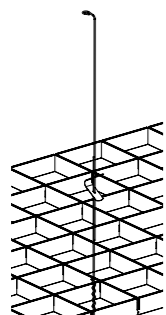

Ø4 mm double hanger with single spring
H40 | H50 | DUALGRID
BASE 4 H30 SC/DUALGRID
BASE 20 H80 | TRIGON

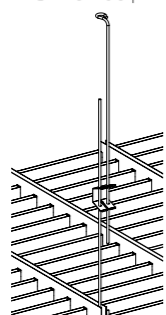

M6 threaded bar
LOGICO | BASE 4 H30 SC
BASE 4 H30 SC/DUALGRID

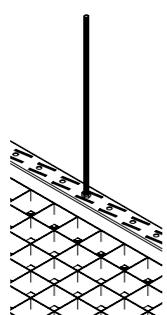

Open cell with T24 - T15 - Easy Line structure

Twister Nonius Standard 90° hanger

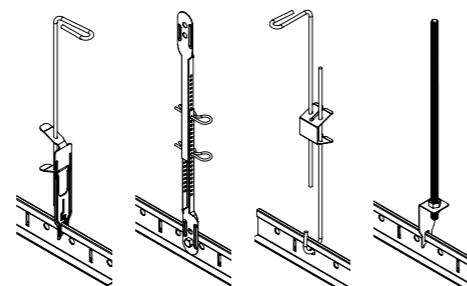

LIGHTING SOLUTIONS

In addition to lighting solutions made up of **recessed lighting elements** or **spotlights with custom made adapters**, Atena Lux signs innovative lighting solutions conceived to **perfectly integrate** the Atena metal ceilings' design.

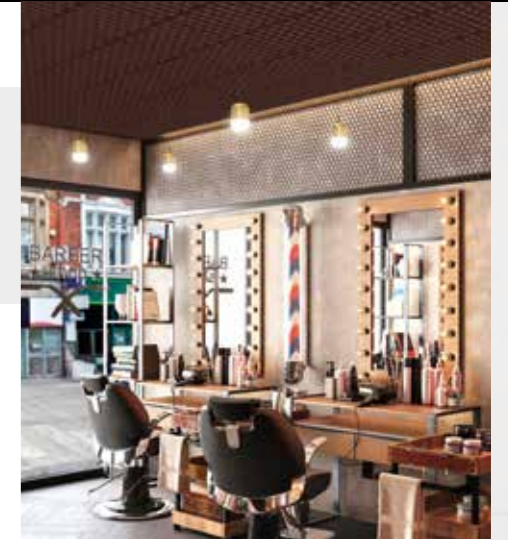

MET G FOR ATENA DUALGRID LIGHTING SYSTEM

Integrated lighting system for ATENA DUALGRID
75x200 mm mesh.



by Atena Lux



PLANG

Integrated solution for ATENA H40 and H50 open cells.

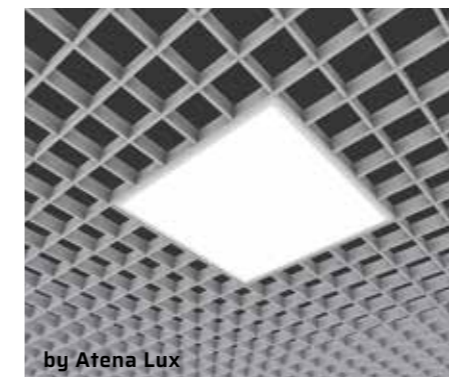

by Atena Lux

4 SIDE G

4SIDE G lay in lighting LED solution for ATENA Base 4 open cell with Easy Line structure.

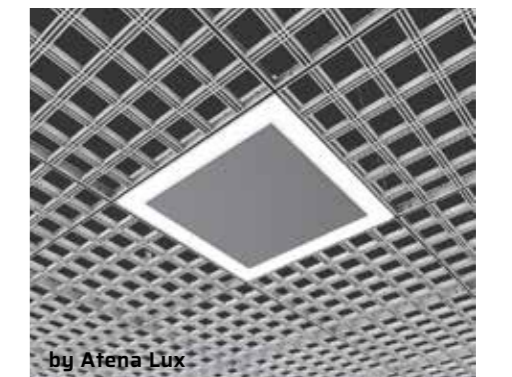

by Atena Lux

WEIGHTS



MESHES	BASE 20 H80	H40	H40 WITH DETACHMENT	H50	H50 WITH DETACHMENT	BASE 15	MESHES	DUALGRID	MESHES	BASE 4		BASE 4 + T		MONOLAMA R-T24
										H18	H30	H18	H30	
50x50	/	4,9	4,5	6,0	5,5	4,7	50x200	3,1	20x20	4,3	6,8	4,1	6,6	/
60x60	/	4,1	3,7	5,0	4,5	3,9	75x200	2,3	30x30	2,9	4,7	2,7	4,4	/
75x75	/	3,3	2,9	4,0	3,5	3,0	100x200	1,9	35x35	/	/	/	/	/
86x86	/	2,9	2,5	3,5	3,0	2,6	150x200	1,4	40x40	2,2	3,6	2,0	3,2	4,40
100x100	4,9	2,5	2,1	3,0	2,5	2,2	/	/	50x50	1,7	2,7	1,6	2,6	/
120x120	/	2,1	1,6	2,5	2,0	1,8	/	/	60x60	1,4	2,3	1,3	2,1	/
150x150	3,3	1,6	1,2	2,0	1,5	1,4	/	/	75x75	1,1	1,8	1,0	1,6	/
200x200	2,5	1,2	0,8	1,5	1,0	1,0	/	/	/	/	/	/	/	/
300x300	1,6	/	/	/	/	/	/	/	/	/	/	/	/	/

SQUARE MESHES	BASE 4 H30 SC 600x600	BASE 4 H30 SC 600x1200	RECTANGULAR MESHES	BASE 4 H30 SC 600x600	BASE 4 H30 SC 600x1200	RECTANGULAR MESHES	BASE 4 H30 SC 600x600	BASE 4 H30 SC 600x1200
40x40	4,80	4,22	30x60	4,80	4,22	80x40	-	3,36
50x50	4,12	3,53	30x100	4,35	3,76	80x50	-	3,02
60x60	3,67	3,08	30x120	4,23	3,65	80x120	-	2,23
100x100	2,76	2,17	30x150	4,12	3,53	80x150	-	2,11
120x120	2,53	1,94	40x100	3,78	3,19	100x40	3,78	3,19
150x150	2,30	1,72	40x120	3,67	3,08	100x50	3,44	2,85
/	/	/	40x150	3,55	2,97	100x60	3,21	2,62
/	/	/	50x100	3,44	2,85	100x150	2,53	-
/	/	/	50x120	3,32	2,74	120x40	3,67	3,08
/	/	/	50x150	3,21	2,62	120x50	3,32	2,74
/	/	/	60x40	3,89	3,65	120x60	3,10	2,51
/	/	/	60x100	3,21	2,62	150x40	3,55	2,97
/	/	/	60x120	3,10	2,51	150x50	3,21	2,62
/	/	/	60x150	2,98	2,40	150x60	2,98	2,40

RECTANGULAR MESHES	BASE 4 H30 SC DUALGRID 600x1200	RECTANGULAR MESHES	BASE 4 H30 SC DUALGRID 600x1200	RECTANGULAR MESHES	BASE 4 H30 SC DUALGRID 600x1200	RECTANGULAR MESHES	BASE 4 H30 SC DUALGRID 600x1200
30x180	6,62	50x180	4,80	100x180	3,44	150x180	2,98
30x270	6,39	50x270	4,57	100x270	3,21	150x270	2,76
40x180	5,48	60x180	4,35	120x180	3,21	/	/
40x270	5,26	60x270	4,12	120x270	2,98	/	/

STRUCTURE	EASY T24	EASY FOX	EASY EASY ANTISIS.	EASY T15	EASY LINE
Kg/ mq	1,24	0,84	1,24	0,96	1,20

MESHES	TRIGON	STRUCTURE	EASY T24 EASY ANTISISMICO (3700-1200)	
			H38	H32
120x120	3,07	Kg/ mq	0,77	0,81
150x150	2,45			
200x200	1,84			

MODEL	BLADES	PITCH	SYSTEM WEIGHT	
			Ste. Blades	All. Blades
			Kg/m ²	Kg/m ²
LOGICO	B100 H100	100	13,87	9,17
	B100 H120	100	15,12	9,61
	B100 H150	100	17,01	10,27
	B100 H100	120	10,75	7,49
	B100 H120	120	11,62	7,79
	B100 H150	120	12,93	8,25

The weights are intended per sqm, structure included. Hangers excluded. For T-frame models, add the relative weight. Regarding the open cell LOGICO, weights refer to the ceiling system both with steel and aluminium blades.



PACKAGING

MODEL	ASSEMBLED PANELS		NOT ASSEMBLED PANELS				2400 mm PROFILE	1200 mm PROFILE	600 mm PROFILE
	A	B	TM		TF		PIECES PER BOZ		
			A	B	A	B			
BASE 20 H80	10	8	212	26	212	26	25	59	212
H40	20	8	424	26	424	26	50	118	424
H40 + T24	20	8	424	26	424	26	/	/	/
H50	16	8	338	26	338	26	34	96	338
H50 + T24	20	8	338	26	338	26	/	/	/
DUALGRID	10	6	118	26	424	26	50	/	/
BASE 4 H18	*	*	400	96	400	96	* (1800 mm)	*	*
BASE 4 H30	*	*	250	96	250	96	* (1800 mm)	*	*
BASE 4 H18 + T24 T15 EASY LINE	*	*	400	*	400	*	/	/	/
BASE 4 H30 + T24 T15 EASY LINE	*	*	250	*	250	*	/	/	/
LOGICO									*
TRIGON									*
MONOLAMA R-T24									*
BASE 4 H30 SC									*
BASE 4 H30 SC D.									*

MODEL	ASSEMBLED PANELS		NOT ASSEMBLED ELEMENTS					
	A	B	TM		TF		L	
			A	B	A	B	A	B
BASE 15	22	8	300	26	300	26	400	120

A = pieces per box B = box per pallet L = base 15 open cell panels lateral elements.

* Variable packaging according to the quantity.



HIGH PERFORMANCE SYSTEMS

CERTIFICATIONS

INTERNATIONAL TECHNICAL STANDARDS



Certifications

ATENA-IT.COM

Picture: "Open cell panels" metal ceiling

PERFORMANCE



	FLEXION RESISTANCE	Maximum span mm 1200 - 1 Class EN13964
	CORROSION RESISTANCE	Galvanized steel products: C2 Class Pre-painted galvanized steel products: C3 Class Post-painted galvanized steel products: C4 Class Pre/post-painted aluminum products: C5 Class
	(RH%) RELATIVE HUMIDITY RESISTANCE	Galvanized steel products: ≤ 90% Pre/post-painted galvanized steel products: > 90% Stainless steel and aluminium products: > 90%
	FIRE REACTION UNI EN 13501-1	A1 Class
	CLEANING	Wet cloth with warm water and neutral non-abrasive detergents.
	COLOR STABILITY	In compliance with technical tolerances standard. Test according the ΔE - CIELab method. ISO 7724-2 (3)
	PAINTED ITEMS DURABILITY	C Class EN13964
	GALVANIZED ITEM DURABILITY	B Class EN13964
SUSTAINABILITY Data declared according to ISO 14021 standard and validated during the EPD verification. Type III environmental labelling.		
	RECYCLED PRODUCT CONTENT	Compliance CAM 2.5.8
	GREEN BUILDING	Requirements compliance: LEED® BREEAM® WELL™ CAM 1.3.4
	MATERIAL DEMOLITION AND REMOVAL	Non hazardous waste in compliance with CAM 2.6.2.
	GREEN ENERGY	Renewables prevalent use CAM 1.2
	DISASSEMBLY	Steel Aluminium 100% recyclable CAM 2.6.2 2.4.14
	WASTE MANAGEMENT	Compliance CAM 2.6.2.
	ACOUSTIC PERFORMANCE	Non applicabile
	BIM DESIGN AND MAINTENANCE PLAN OF THE WORK	CAM 2.7.3 2.4.13
	SVHC PRESENCE	Compliance CAM 2.5.7
	FORMALDEHYDE	Absent E1 Class CAM 2.5.1. 3.2.8
	RELEASE OF DANGEROUS SUBSTANCES	None CAM 2.5.1. 3.2.8 EN13964
		Requirement 2.5.1 - Compliance on all products. Rewarding requirement 3.2.8 - Compliance for post painted products with "Gold Leaf" high performance coating.



TECHNICAL STANDARDS

All Atena metal ceilings are produced for **internal use** according to the technical rules for construction NTC 2018 and UNI EN 13964 standard.

For **external application**, metal ceilings and coverings have to be dimensioned on environment features, to list some of the possible examples: earthquakes, wind, thermal expansion, place of installation, use destination of the building and project requirements.

According to NTC 2018 and EUROCODICI each Atena product for interior application has its own D.o.P. (Declaration Of Performance) CE mark according to the European Law 305/2011.



BEARING CAPACITY AND FLEXION RESISTANCE

Limit states of **bearing and flexion resistance** of Atena structures and panels are reported in technical data sheets. Atena panels are classified in 1st Class of flexion resistance. Structures have generally a **maximum span of 1200 mm**. According to Technical Norme for Construction - D.M. 14/01/2018, **lighting elements and accessories must be fixed directly to the concrete and not load the metal ceiling system.**

According to the engineering criteria of metal ceilings, panels are tested to support their mass and to maintain flatness and curvature properties. On request Atena S.p.A. can conceive and produce panels suitable to support additional loads, that must be clearly specified in terms of quantity, position and application modes.



COLOUR TOLERANCE

Atena S.p.A. has a **quality control management system** to ensure the **compliance with law requirements** in force and technical standard tolerances. All color controls included those on products made in different production periods or made and processed using raw materials and powders from different lots, are verified and test by Atena according the **ΔE - CIELab method**.



INDOOR WIND LOAD RESISTANCE

For the calculation on the panels mechanical strength Atena S.p.A. considered the vertical dead load. **Any upward thrusts** that can overcome the dead weight of the metal ceiling **should be checked at project stage** by identifying critical areas where upward thrusts can occur, such as in entrances, near the doors or windows, on the corners of buildings, in the presence of large or permanent openings such as car parks or access routes. In all these cases, the ceiling must be dimensioned to withstand any wind aspirations or pressures.

DURABILITY

Atena metal ceilings are made of galvanized and painted materials suitable to the different **durability exposure classes** as set in UNI EN ISO 13964. Specifically, galvanized steel products are classified in exposure B class, painted steel products in C Class, the stainless steel and aluminum elements in D Class.

On request Atena S.p.A. can proceed with special treatments against galvanic and chemical corrosion in the most critical conditions.

EXPOSURE CLASS	ENVIRONMENT CONDITIONS	PRODUCTS DURABILITY CLASSIFICATION
A	Buildings frequently exposed to relative humidity up to 70% and varying temperatures up to 25°C but with no corrosive pollutants.	Atena galvanized steel products
B	Buildings frequently exposed to relative humidity up to 90% and varying temperatures up to 30°C but with no corrosive pollutants.	Atena galvanized steel products
C	Exposure to an atmosphere with 90% humidity level and risk of condensation.	Atena post-painted steel, Stainless steel and aluminum products
D	Critical conditions.	Atena products with specific treatment on request

The **durability** of a material/component is the **capability to maintain its performance properties and perform the required functions** during a defined period; Since the "moment zero", when the component is installed and put into operation, to the "end of its life cycle".

The **performance properties** declared in D.o.P. (Declarations of Performance) provided by Atena S.p.A. are guaranteed, if the metal ceiling is installed in the environment conditions for which it has been conceived, the recommended maintenance is executed and it is not affected from inadequate treatments such as tampering, cuts, abrasion, damages which can interrupt the coated layer, please check with Atena's technical department the specific environmental conditions to which the product will be submitted in order to choose the most suitable material.

FIRE REACTION

All Atena metal ceilings comply with the Euroclass standard for building materials; systems, with holed or metal membrane with acoustic tissue "PLUS", are incombustible and come into **A1 Class**.

CHEMICAL CORROSION PROTECTION

According the UNI EN ISO 13964 standard all steel and aluminum components must be protected against corrosion in relation to exposure class. The material corrosion is a natural and irreversible deterioration process of the physical properties due to its slow and continuous consumption. The **corrosion resistance** is indicated as **low, medium** or **high**, near the **environment corrosion class**, in order to evaluate the performance of the coating in the environment and under operating conditions. It should be understood as an **indication of the effectiveness of a protection treatment for a given period of time**.

UNI EN ISO 12944-1 durability classes

- Low (L) = from 2 to 5 years
- Medium (M) = from 5 to 10 years
- High (H) = over 15 years

This is not a guarantee of durability, but an indication to schedule the maintenance tasks necessary to keep the **material's properties in relation to its life cycle**.

The durability tests based on the corrosion classes conducted by the Istituto Giordano S.p.A. on the galvanized steel, post-painted galvanized steel, pre-painted galvanized steel and aluminum Atena components used for the construction of metal ceilings, report excellent corrosion resistance and have been classified in **C5-M media**. Tests were carried out in compliance with UNI EN ISO 6270-2:2005 and 12944-6:2001 standards in humidistatic chamber with humidity atmospheres for the determination of moisture resistance and the protection of steel structures coating against corrosion. The excellent result has been confirmed by the **corrosion resistance tests in salt fog** conducted by the Istituto Giordano S.p.A. according to UNI EN ISO 9227:2012. As the laboratory environment can not represent the normal conditions of use, Atena S.p.A., according to its experience, recommends the choice of materials according to the classification given in the schedule on page 50.

PROTECTION AGAINST GALVANIC CORROSION

Electrochemical corrosion is due to the **contact of materials with different potentials** that produce galvanic currents.

In these cases Atena recommends the use of **polymer separators and/or the use of post-painted polyester-coated galvanized materials with at least 60 µm**; the paint is a good protection against galvanic corrosion in environment conditions that do not deteriorate the coated layer.

For specific applications, please check with Atena technical department the proper material according to the application field.

CLASS OF CORROSIVITY	INTERNAL ENVIRONMENTS	OUTDOOR ENVIRONMENTS
C1 VERY LOW $r_{corr} \leq 0,1^*$	NOT AGGRESSIVE ENVIRONMENT	Low humidity in heated environment, no pollution.
C2 LOW $0,1 < r_{corr} \leq 0,7^*$	LITTLE AGGRESSIVE ENVIRONMENT	Temperatures and variable humidity in an no-heated environment, low pollution and moisture values.
C3 AVERAGE $0,7 < r_{corr} \leq 2^*$	AVERAGE AGGRESSIVE ENVIRONMENT	Moderate presence of moisture and pollution due to light productive processes.
C4 HIGH $2 < r_{corr} \leq 4^*$	AGGRESSIVE ENVIRONMENT	Frequent moisture and high pollution levels due to industrial processes and sports pools.
C5-I VERY HIGH C5-M MARINE $4 < r_{corr} \leq 8^*$	HIGH AGGRESSIVE ENVIRONMENT	Caves. Very serious pollution (SO ₂ up to 250 µg/m ³); Areas with heavy industrialization, buildings on the coast.

* ENVIRONMENTAL CLASSIFICATION AND CORROSION RATES r_{corr} [≅] µm/year (zinc thickness loss)

Source: ISO 9223 - Corrosion of metals and their alloys - UNI EN ISO 14713 - Zinc Coatings, guidelines and recommendations



GREEN ENERGY

CAM 1.2 | GREEN BUILDING REQUIREMENTS

The production plant is mainly powered by **renewable sources** through high-performance photovoltaic systems.



GREEN BUILDING REQUIREMENTS

CAM 1.3.4 | GREEN BUILDING REQUIREMENTS

Get credits for building certification according to the **LEED® | BREEAM® | WELL™** standards, by using Atena products. The evidence of compliance can be used in the C.A.M. report.



RECYCLED MATERIAL CONTENT

CAM 2.5.8 | GREEN BUILDING REQUIREMENTS

Atena products are, as a whole, **manufactured using recycling processes materials**, the **recycled content** is **calculated for each type of product**, in compliance with C.A.M. requirements and declared according to the ISO14021-ISO14025-EN15804:2012+A2:2019 standards for EPD drafting.



RELEASE OF DANGEROUS SUBSTANCES

CAM 2.5.1 - 3.2.8 | GREEN BUILDING REQUIREMENTS

Atena products **do not release dangerous substances** and do not contain formaldehyde (E1 Class). Paints and sublimations are carried out using VOC-free substances. Compliance on all products for 2.5.1 requirement. Rewarding requirement 3.2.8 for post painted products with "Gold Leaf" high performance coating.



CONTENT OF SVHC

CAM 2.5.7 | GREEN BUILDING REQUIREMENTS

Atena uses raw materials **free of SVHC** very high concern substances listed in "Candidate list of SVHC" released by the European Chemical Agency.



DISASSEMBLABILITÀ

CAM 2.6.2 - 2.4.14 | GREEN BUILDING REQUIREMENTS

Atena steel and aluminum products are **100% recyclable** and at the end of their life cycle can be prepared for re-use, recovery, recycling and selective demolition.



MATERIALS DEMOLITION AND REMOVAL

CAM 2.6.2 | GREEN BUILDING REQUIREMENTS

At the end of their life cycle, the Atena products become **non-hazardous waste** that can be prepared for re-use, recovery or recycling.



WASTE MANAGEMENT

CAM 2.6.2. | GREEN BUILDING REQUIREMENTS

Atena uses **recyclable** packaging.



BIM DESIGN AND MAINTENANCE PLAN OF THE BUILDING

CAM 2.7.3 - 2.4.13 | GREEN BUILDING REQUIREMENTS

Atena provides the **BIM model** of its products and systems including the applicable environmental information, therefore the Atena BIM model is useful both for achieving a rewarding score and for the **building end-of-life plan drafting**.

Quality, environment, health, safety: together for a sustainable architecture

Atena's commitment to **Environmental Sustainability** and **Safety** passes through all main company processes to produce safe products, whose use contributes to the construction of **high performance buildings**, conceived to achieve the **highest levels of comfort, healthiness and respect for the environment**.



Picture: "Open cell panels" metal ceiling

Pictures:
istockphoto.com: p. 4-5-11-17-18-19-21-23-25-27-29-31-35-38-43-45-46-48-50-51
stock.adobe.com: p. 6-7-40-52
unsplash.com: p. 13-15-41

The settings are reinterpreted with photorealistic
reconstructions by Atena S.p.A.
All rights reserved.

INNOVATIVE ARCHITECTURAL SOLUTIONS

All dimensions are nominal and expressed in millimeters.
All weights are expressed net of tare.
All technical specification data and information can be changed without advise.
More details concerning colours, perforations, perimeter profiles and laying
instructions are described in technical data sheets suitable on line: atena-it.com
For further information please contact sales department:
tel. + 39 0421 75526 commerciale@atena-it.com



ISO 9001



FALSE CEILINGS AND COVERINGS

Atena S.p.A.
Via A. De Gasperi, 52 - 30020 Gruaro (VE) Italy
Ph: +39 0421 75526 - Fax: +39 0421 75692
atena-it.com - info@atena-it.com